

PAB

Atex-certified centrifugal pumps



Technical data

- Delivery rate
 $Q_{\max} = 305 \text{ l/min}$
- Delivery head
 $H_{\max} = 20 \text{ m}$
- Temperature range
 0°C to $+60^{\circ}\text{C}$



Main areas of use

- Printing machines
- Packaging machines
- Surface coating
- Washing/degreasing installations
- Impregnation
- Electroplating baths

Their uniform, pulsation-free delivery of fluid makes Spandau centrifugal pumps especially well suited to pumping ink. Their open impeller design allows for small particles in the return flow. Adjustable drive power also makes them suitable for high viscosities.

Fluids delivered

- Inks containing solvents
- Varnishes and oil-based paints
- Water-based paints
- Cleaning fluids
- etc.

Viscosities

1 to 20 mm²/s (more than 20 mm²/s on request)

Temperature range

0 °C to 60 °C

Design features

- Centrifugal pump, pulsation-free
- 1- to 2-stage versions
- Open impellers
- Connector dimensions as per DIN EN 12157
- Variable immersion depths
- Design with detachable aluminum motor with protection class EExd – “explosion-proof enclosure” (PAB-XD group)

Ratings:

Delivery rate Q_{\max} = 305 l/min

Delivery head H_{\max} = 20 m

Special design features of the PAB group

The pump section – consisting of the pump housing and flange-type end shield – is connected to the drive only by quick-release locks. This allows the drive to be removed from the pump component without having to disconnect the electrical leads. Cleaning is simpler and faster as a result. All hydraulic parts of the PAB group are compatible with most cleaning methods.

Mechanical design

Component	PAB
Motor housing	AL
Pump port	GCI with chemical surface sealing
Flange-type end shield	AL
Pump bottom	GCI with chemical surface sealing
Intermediate chamber	GCI with chemical surface sealing
Impeller	Bronze
Shaft	Stainless steel 1.4122
Rotary shaft seal	PTFE in the - Pump flange - Flange-type end shield under the lower ball bearing - Flange-type end shield over the upper ball bearing

Installation and operation

The unit is installed upright. The maximum level for fluid is 20 mm below the mounting flange. Before start-up, fill the pump with fluid for pumping. When pumping, the unit can operate without fluid only for short periods and under certain circumstances. Operation against dead head is possible.

Direction of rotation

Counterclockwise – as viewed looking down on the motor's ventilation side.

Explosion-proofing

Directive 2014/34 / EU (ATEX) applies to equipment and protective systems for intended use in potentially explosive atmospheres areas.

The **ATEX (ATmosphère EXplosible** – potentially explosive atmosphere) applies to all “equipment” (e.g. machines, apparatus, ...) which, “separately or jointly, are intended for the generation, transfer, storage, measurement, control and conversion of energy for the processing of material and which are capable of causing an explosion through their own potential sources of ignition.”

The pump group PAB is ATEX approved –

it is certified and marked accordingly. The corresponding certificates of conformity as well as type approval certificates and/or certificates of deposit are available can be obtained on request.

Technical explanation of electrical versions of drive motors

“Explosion-proof enclosure” protection, EExd

The performance ratings of our pump motors refer to the motor version for explosion group IIC. The stated performance ratings and operating values are valid for ignition class T4. These ratings and values encompass all lower explosion groups and temperature classes.

The motors have the following coding according to EN 60079-1: II 2G EX de IIC T4 Gb

The pumps have the following coding according to EN 60079-1: PAB II 2 G c IIB T4

The stated performance ratings and operating values are valid for mode S1, the rated frequency and voltage, a maximum coolant temperature (ambient temperature) of 40 °C, and a site altitude of up to 1000 m above sea level.

The motors of the pumps normally come with a 6-pole terminal board for 230/400 V, delta/star. Upon delivery we switch the motors to the higher star-connected voltage of 400 V.

The voltage tolerance permissible in operation is $\pm 5\%$ at the rated power and frequency, in compliance with EN 60034.

Hazardous areas

The user has sole responsibility for deciding which explosion group is to be applied. In case of doubt, the relevant supervisory body may decide which protective measures are required to prevent harm. DIN 57165 and VDE 0165 classify hazardous areas into zones.

Zone	Motor with protection class Exd – “explosion-proof enclosure”
0	Not permitted
1	Permitted
2	Permitted

Order information, PAB

Type code (pump component)	P	A	B					C	A	A									
Group																			
Size																			
	05, 07, 08, 11, 20																		
Number of stages																			
	01 = 1-stufig																		
	02 = 2-stufig																		
Material																			
	C = GCI with chemical surface sealing																		
Pump design																			
	AA = Standard design																		
Immersion depth in mm																			
	170, 220, 250, 270, 350, 440																		
For motor																			
	E = 0,37 kW F = 0,55 kW G = 0,75 kW H = 1,1 kW																		
Impeller																			
	50 = 50 Hz impeller 60 = 60 Hz impeller																		

Type code (motor)	P	A	B	-					R	D
Group										
Motor index										
	E = 0,37 kW F = 0,55 kW									
	G = 0,75 kW H = 1,1 kW									
Power supply										
	30 = 220–240 V, 50 Hz (delta)									
	380–415 V, 50 Hz Y									
	254–280 V, 60 Hz (delta)									
	440–480 V, 60 Hz Y									
	31 = 200 V, 50 Hz (delta)									
	345 V, 50 Hz Y									
	220–230 V, 60 Hz (delta)									
	380–400 V, 60 Hz Y									
Motor design *										
	RD = Motor protected by explosion-proof enclosure									
	Exd II 2G EX de IIC T4									
	* Other designs on request									

Order information

The pumps in the PAB group are supplied in two components, a pump component and a motor component. The type codes for the pump component and motor component therefore need to be configured separately.



PAB – Dimensioned drawing and characteristics

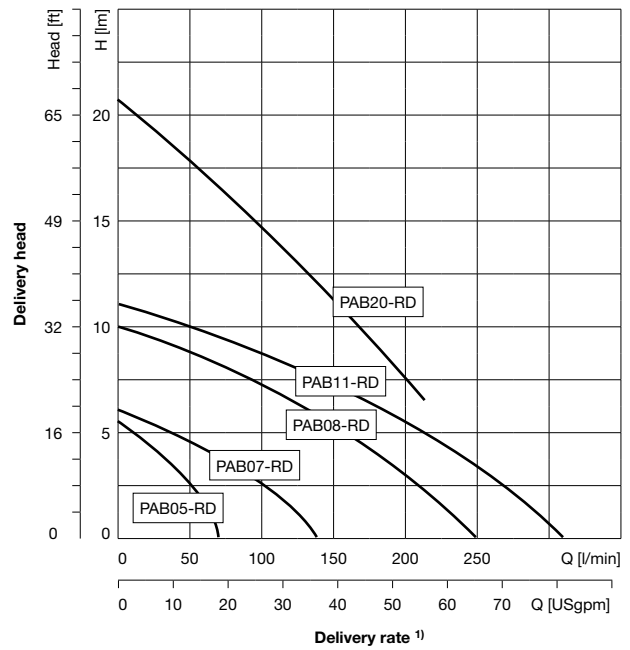
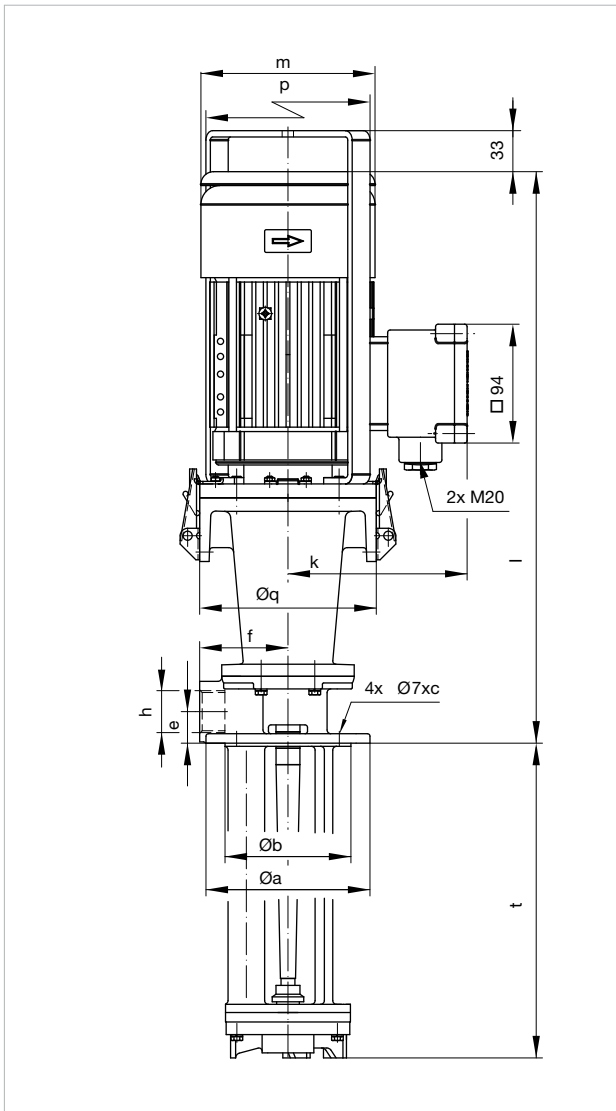

1) Data for viscosity of ~1 mm²/s at a density of ~1 kg/dm³. Minimum volumetric flow: 5 to 10 % of nominal delivery rate.

PAB – Electrical values, dimensions, and weights

Model	Immers. depth t [mm]	Dimensions [mm]										Weight [kg]	Sound pressure [dBA]	Pressure port (DIN ISO 228)	Frequency [Hz]	Motor ratings 230/400 V				
		Øa	Øb	Øc	e	f	k	l	Øm	Øq	p					Power P _N [kW]	Current ΔI _N [A]	Current YI _N [A]	Speed n _N [min ⁻¹]	Index
PAB05-RD	170	130	100	115	25	70	142	450	138	140	164	13-14	62,5	G 1	50	0,37	2,0	1,2	2770	E
	220															0,43			3320	
	250																			
	350																			
PAB07-RD	170	130	100	115	25	70	142	450	138	140	164	13-14	62,5	G 1	50	0,37	2,0	1,2	2770	E
	220															0,43			3320	
	250																			
	350																			
PAB08-RD	230	180	140	160	32	100	142	480	138	160	164	21-23	63	G 1 1/4	50	0,55	2,9	1,7	2710	F
	270															0,60			3250	
	350																			
	440																			
PAB11-RD	230	180	140	160	32	100	151	496	156	160	183	23-25	63,7	G 1 1/4	50	0,75	3,45	2,0	2820	G
	270															0,68			3380	
	350																			
	440																			
PAB20-RD*	270	180	140	160	32	100	151	496	156	160	183	29	65	G 1 1/4	50	1,10	4,5	2,6	2810	H
															60	1,27			3420	

* 2-stage

The contents of this publication are the copyright of the publisher and may not be reproduced (even extracts) unless our written permission is granted. Every care has been taken to ensure the accuracy of the information contained in this publication, but no liability can be accepted for any loss or damage whether direct, indirect or consequential, arising out of use of the information contained herein.

SKF Lubrication Systems Germany GmbH
Product department Spandau Pumps
Motzener Strasse 35/37 · 12277 Berlin · Germany
PF 970444 · 12704 Berlin · Germany
Tel. +49 (0)30 72002-0 · Fax +49 (0)30 72002-261
www.spandaumpumpen.com

This brochure was presented to you by: