

Gerotor Pumps

Product series 143

for oil
for use in SKF CircOil centralized lubrication systems

Gerotor pump unit in foot design



Gerotor pump unit in flange design



Gerotor pump+pump flange+ shaft coupling



SKF gerotor pump units of product series 143 are self-priming positive-displacement pumps with fixed displacement and high efficiency. They are used in SKF CircOil centralized lubrication systems for a variety of tasks and applications, especially in circulating-oil and total-loss lubrication systems.

The durable and rugged gerotor pump unit was designed and manufactured in Germany.

Fields of application

- General mechanical and plant engineering
- Shipbuilding and offshore industry
- Paper, printing, and pulp industries
- Heavy industry

Advantages

- Flexible delivery range from 0.85 to 50 l/min at system pressures up to 50 bar
- Large viscosity range for standard mineral and synthetic lubricating and hydraulic oils from 20 to 1000 mm²/s
- Ambient temperature of 0 to +40°C

- Low volumetric flow pulsation and thus very smooth running
- Gerotor with a cycloid contour and thus good suction characteristics
- Low-noise
- Gerotor pumps are available in NBR and FKM (FPM) designs.
- Squirrel cage motors are available in different voltage designs for 50 and 60 Hz.
- Compact design
- Modular ordering system (order as a complete pump unit, single pump, or pump with flange and shaft coupling)

SKF

Contents

Illustration of designs and accessories	3	IEC squirrel cage motors	
Gerotor pumps, product series 143		Principles	14–15
Principles	4–5	Rating plates	15
Technical data	6	Voltage code	16
Order code	7	Technical data	17
Designs, installation drawings, and dimensions		Motor data	17
Gerotor pump	8	Installation drawings and dimensions	18
Gerotor pump+pump flange	9	Viscosity-temperature relationship of oils	19
Coupling assembly	9	Exploded view	
Motor connection	9	Spare parts	21
Foot and flange designs	10–11	Comparison of old and new order Nos.	22–23
Characteristic curves	12–13		



Note:

The technical data in this publication provide for general information. Follow the assembly instructions and any instructions on and accompanying the products when performing assembly, operating, and maintenance. Technical data and selection and ordering data, including availability, for accessories are subject to change.



Important information on product usage

All products from SKF may be used only for their intended purpose as described in this brochure and in any instructions. If operating instructions are supplied with the products, they must be read and followed.

Not all lubricants are suitable for use in centralized lubrication systems. SKF does offer an inspection service to test customer supplied lubricant to determine if it can be used in a centralized system. SKF lubrication systems or their components are not approved for use with gases, liquefied gases, pressurized gases in solution and fluids with a vapor pressure exceeding normal atmospheric pressure (1 013 mbar) by more than 0,5 bar at their maximum permissible temperature.

Hazardous materials of any kind, especially the materials classified as hazardous by European Community Directive EC 67/548/EEC, Article 2, Par. 2, may only be used to fill SKF centralized lubrication systems and components and delivered and/or distributed with the same after consulting with and receiving written approval from SKF.

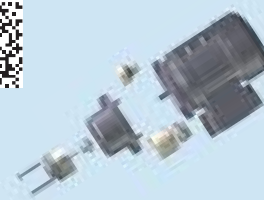

CAD models for the products shown in this brochure can be downloaded at: skf-lubrication.partcommunity.com

Gerotor Pumps

Illustration of designs and accessories

Gerotor pump unit in foot design



Gerotor pump unit in flange design



Gerotor



Gerotor pump



Pump flange



Shaft coupling



ICE squirrel cage motor



Gerotor pump+pump flange+ shaft coupling



Gerotor pumps, product series 143

Fundamentals

General use

SKF gerotor pump units of product series 143 are used in circulating-oil and total-loss lubrication systems in a flow rate range of 0.85 to 50 l/min. The standard permissible ambient temperature is between 0 and +40 °C. Higher ambient temperatures are possible, though they lead to a reduction in motor performance and thus the delivery rate. The permissible temperature of the pumped medium is between 0 and +80°C. The gerotor pumps are available in NBR and FKM (FPM) designs.

SKF gerotor pump units feed lubricating and hydraulic oils from a reservoir and into the pipe system of a centralized lubrication system. In doing so, they increase the energy of the pumped medium (pressure increase) to overcome flow resistance in the pipelines (pressure loss), the components (filters, valves, distributors) and the bearings and friction points. SKF gerotor pump units of different types and performance ratings are used depending on the type and size of the centralized lubrication system and the lubricant.

Applications

The main area of application is the broad field of circulating-oil and total-loss lubrication systems for general mechanical engineering and plant engineering applications. Here, the focus is on lubricating and cooling heavily loaded bearings and friction points for a wide range of uses. SKF gerotor pump units are used primarily as lubricating, hydraulic, hydrostatic, and cooling oil pumps. They can be set up either as single pumps or integrated into a reservoir unit. Other areas include the shipbuilding and offshore industry as well as the paper, printing, pulp, and heavy industries.

Delivery rates and characteristic curves

The nominal delivery rates indicated in the catalog refer to the nominal output multiplied by the speed of the motor. The actual delivery rate changes with operating viscos-

ity and back pressure and can be found in the characteristic curve diagrams in the catalog. These diagrams are based on the range between 20 and 1000 mm²/s in increments of 20, 140, 750, and 1000 mm²/s. Each gerotor pump has a characteristic curve represented as a function of the delivery rate above the delivery pressure (back pressure).

It is important to note that temperature influences can render lubricating and hydraulic oils extremely thin or viscous. Please consult with us in advance if you will use lubricating and hydraulic oils with an operating viscosity outside the specified range.

SKF CircOil centralized lubrication system

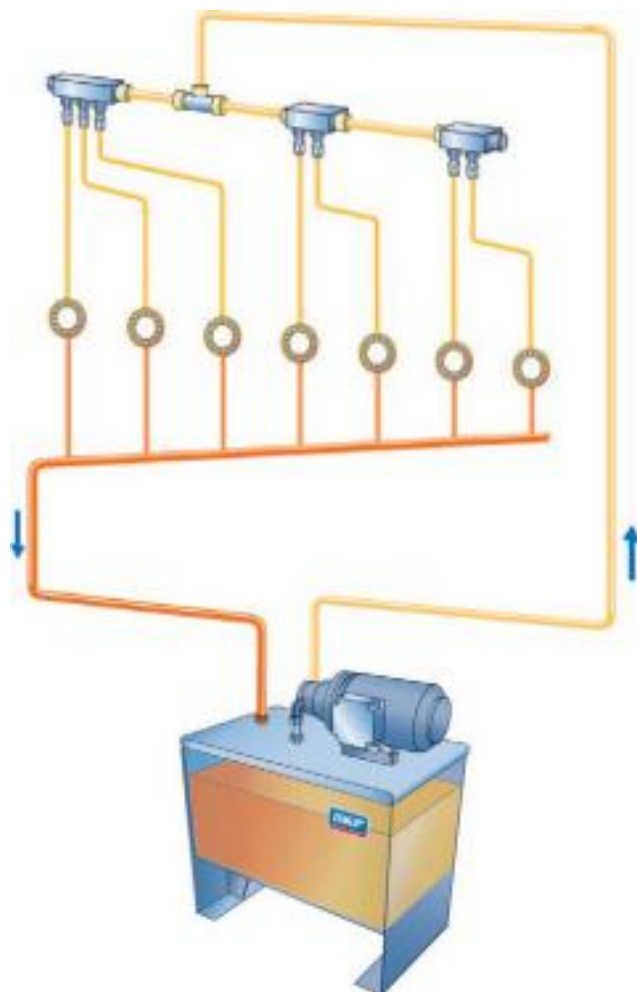

Gerotor pumps, product series 143

Fundamentals

Design (Figure 1)

SKF gerotor pump units of product series 143 have a constant displacement volume and one delivery circuit.

The annular-toothed feeding element, also referred to as the gerotor, is equipped with a cycloid contour, which creates a large tooth meshing length. This yields a low volumetric flow pulsation and thus very smooth running, low noise production, and good suction characteristics.

SKF gerotor pumps consist primarily of pump housing (1), the shaft (2), the displacement elements toothed rotor (3) and annular gear (4), and the lid (5).

Suction and displacement process (Fig. 1)

The shaft drives the centrally mounted toothed rotor in the indicated direction of rotation via a feather key. The toothed rotor meshes with the outer, eccentrically mounted annular gear and rotates with it. The openings between teeth arising in the suction area (S) draw the pumped medium in. The suction and pressure area is separated from the tooth meshing area (Z) by a radial gap (R) formed by the tooth profiles of the annular gear and the toothed rotor as they slide onto one another. In the pressurized area (P), the fluid is fed to the pressure port through increasingly small chambers.

Drive

SKF gerotor pump units of product series 143 are driven by IEC squirrel cage motors sized 63 to 132 in the standard design. The motors are designed for a rated motor voltage of 230/400 V or 400/690 V for 50 networks according to DIN IEC 60038. The normal coils used here in motors with performance < 0.75 kW are designed for the wide voltage range. The normal coils in motors with performance ≥ 0.75 kW are tailor-made and meet the IE2 efficiency level according to EU Directive 2009/125/EC. Special voltage versions with special coils for 50 Hz and 60 Hz networks are available for order.

The standard design of the motors comes with a terminal box. Motors with UL/CSA certification are available. Further certifications are available on request.

Shaft coupling

The shaft couplings are designed as curved-tooth couplings. Curved-tooth couplings are flexible shaft connections for positive torque transmission. The material combination of steel hub and polyamide sleeve used for the curved-tooth couplings permits maintenance-free continuous duty with very low friction on the teeth. They, therefore, do not require any lubrication or maintenance and are nearly wear-free in operation.

Installation

SKF gerotor pump units of product series 143 can be installed both horizontally and vertically. Foot or flange versions are available for each gerotor pump unit design.

When the gerotor pump unit is set up separately from the reservoir, the suction port on the pump can be connected to a reservoir at a higher position (max. 2000 mm).

To flange the gerotor pump unit to a reservoir horizontally below the oil level, use a sealed pump in a special design. Please consult our Engineering department in advance.

In its design as a pump with flange and coupling, various technical designs of customer-specific electrical motors can be used. The flange allows for the installation of all IEC standard motors with a flange according to DIN EN 50347, design FT (with threaded holes). See the drawings in this publication for the geometric dimensions of the flange.

If only gerotor pumps without a motor are used, for example as an integrated/attached pump on a machine housing, ensure that no radial or axial load is applied to the drive shaft. The pumps can be installed in any position.

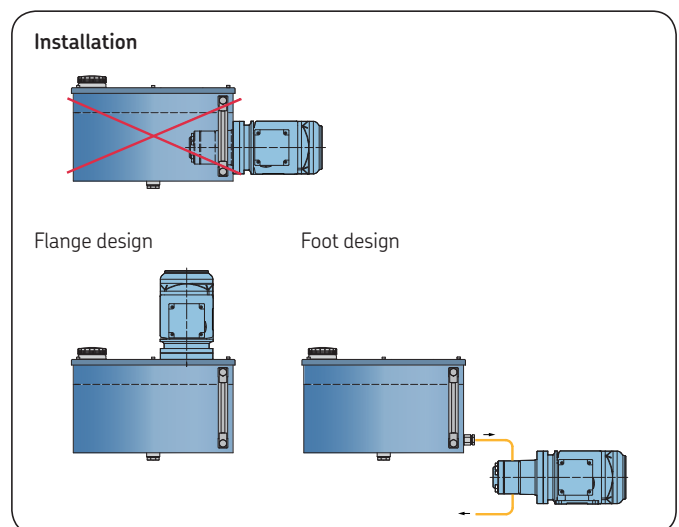
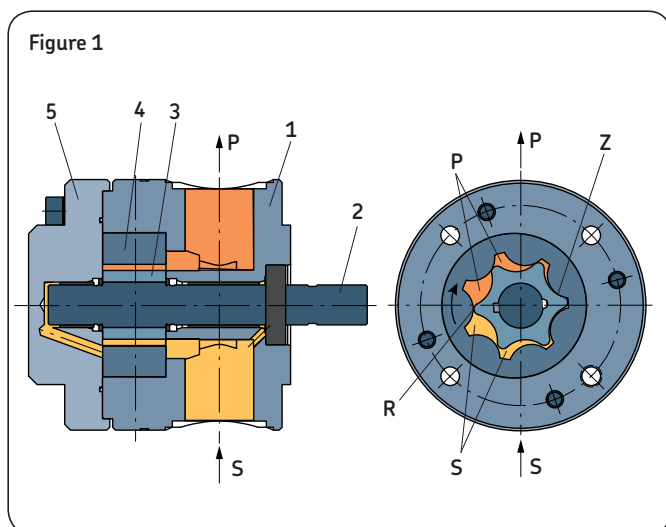

Gerotor pumps, product series 143

Technical data

Gerotor pump unit in foot design



Gerotor pump unit in flange design



Gerotor pump



Technical data

Flow rate range	0.85 to 50 l/min
Pressure, max.	50 bar
Pumped medium	Lubricating and hydraulic oils
Operating viscosity	20 to 1000 mm ² /s
Drive speed depending on design	1400 and 2800 rpm
Protection class acc. to DIN EN 40050	IP54
Duty type per VDE 0530	S1
Ambient temperature range	0 to +40 °C
Pumped medium temperature range	0 to +80 °C
Sealing material	NBR, FKM (FPM)
Suction head, max.	1000 mm
Operating noise level	Max. 60 dBA
Varnishing	RAL 7024 graphite gray, special varnish available on customer request

Materials

Pump housing	Hydraulic cast (pressure-tight) with good wear and antifrictional properties
Tooth ring insert	Sintered material
Shafts	Low-deformation case-hardened steels
Bearing	SKF plain bearing

! General notes on usage

During commissioning, pay attention to the pump's direction of rotation. See the rating plate and motor rotation arrow on the pump.

If using the pumps in systems without any open pressure lines, provide pressure-regulating valves to limit the maximum pressure of the system.

The selected cross-section of the intake tube must be equal to or greater than the cross-section of the pump's suction port.

SKF Lubrication Systems Germany AG recommends the use of filters for trouble-free operation of the pumps or pump units. Effective filtration prevents malfunctions while also increasing the service life of the pumps. A pumped medium of at least the purity class 20/17/14 according to ISO 4406(c) is recommended. This corresponds to the U.S. standard NAS code (1638) class 8 and SAW AS 4059 class 8. A filter rating of approx. 5 - 10 µm meets this requirement. The filter rating used is always based on the most sensitive component in the entire system. This is not necessarily the pump.

Gerotor pumps, product series 143

Order code

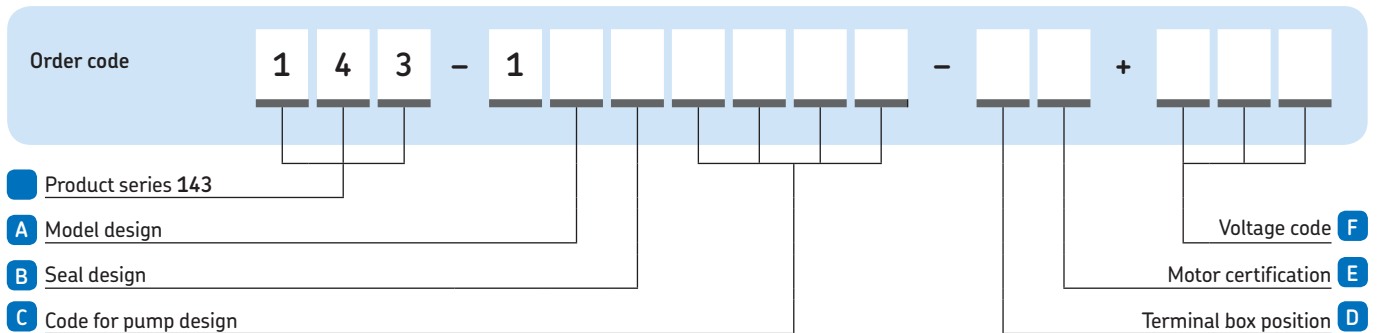

Model design

- A 1** Motor in foot design (IMB34)
- 2** Motor in flange design (IMB14)
- 3** Gerotor pump+pump flange+ shaft coupling (without motor)
- 4** Only gerotor pump (without motor)

Seal design

- B N** NBR
- F** FKM (FPM)

Terminal box position as seen from shaft extension of drive side (not applicable on design without motor)

- D R** Right (standard, not on motor 1.1; 1.5, and 4 kW)
 - O** Top (standard on motor 1.1, 1.5, and 4 kW), right not supported
 - X** On motor in flange design (IMB14), Terminal box position on suction port side of pump
- (others available on request)

Motor certification

Not applicable on design without motor

- E A** CE (Europe)
 - B** UL/CSA (USA/Canada)
- (others available on request)

Voltage code

Not applicable on designs without motor

- F XXX**

Voltage code **See page 16.**

Code for pump design

Code	Nominal delivery rate ¹⁾ [l/min]	Back pressure max. [bar]	Motor drive power [kW]	Permissible operating viscosity range [mm ² /s]	Size	Number of poles
B03C	0.85	30	0.18	20-1000	63	4
D03E	1.7	30	0.37	20-1000	71	2
F02D	2.5	20	0.25	20-1000	71	4
F05F	2.5	50	0.55	20-1000	80	4
H02F	5.25	20	0.55	20-1000	80	4
H05J	5.25	50	1.1	20-1000	90	4
K02H	9	20	0.75	20-1000	80	4
K05J	9	50	1.1	20-1000	90	4
M02H	12.5	20	0.75	20-1000	80	4
M05K	12.5	50	1.5	20-1000	90	4
P02K	19	20	1.5	20-1000	90	4
R02M	30	20	3	20-1000	100	2
R03M	30	30	3	20-750	100	2
R03N	30	30	4	20-1000	112	2
T02M	40	20	3	20-750	100	2
T03N	40	30	4	20-1000	112	2
V02N	50	20	4	20-1000	112	2
V03N	50	30	4	20-750	112	2
V03P	50	30	5.5	20-1000	132	2

¹⁾ Nominal delivery rate at motor speed 1400/2800 rpm acc. to number of motor pins.

Order example

143-11ND03E-RA+1FX

- Gerotor pump unit
- Product series 143
- Motor in foot design
- Sealing NBR
- Nominal delivery rate 1.7 l/min
- Back pressure 30 bar
- Motor index 0.37 kW
- Terminal box on right
- Motor certification CE
- 220-240 V / 380-420 V, 50 Hz
- 254-280 V / 440-480 V, 60 Hz

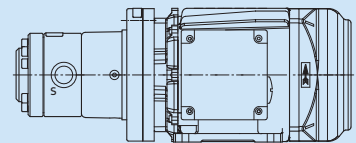

D - F is not applicable if ordering the gerotor pump+pump flange+shaft coupling (model design 3)

Example: **143-13ND03E**

D - F and item 4 of the code for the pump design are not applicable if ordering the gerotor pump (model design 4)

Example: **143-14ND03**

Gerotor pumps, product series 143

Gerotor pump design, technical data and dimensions

Figure 2

Gerotor pump

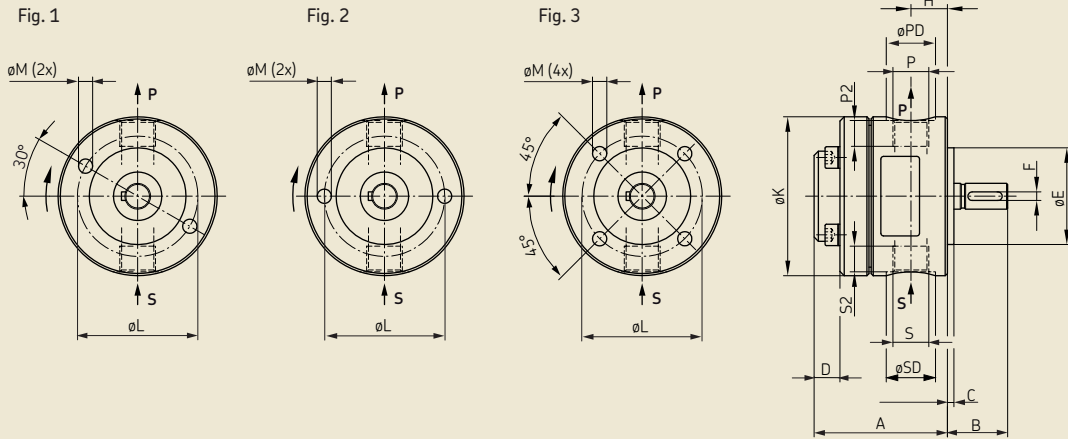

Shaft extension

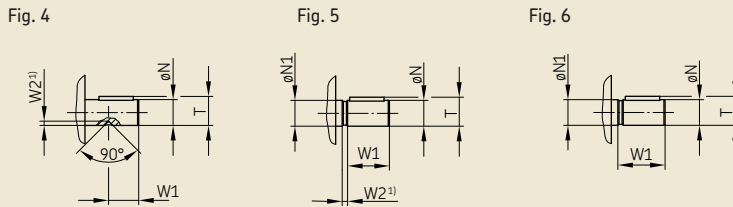

↑ = direction of rotation

¹⁾ For securing the coupling boss in axial direction

Gerotor pump (→ Fig. 2)

Nom. dev. rate [l/min]	Back press. max. [bar]	Permiss. viscosity range [mm ² /s]	Char. curve No.	Nominal output [cm ³ /rev.]	Speed [rpm]	Required drive power [kW]	Intake port S ²⁾	Press. port P ²⁾	Design N (NBR) / F (FKM / FPM)	Dimensions [mm]													Fig.				
										Order No. ⁴⁾	A	B	C	D	øE	F	H	øK	øL	øM	øN	øN1		P2 S2	T	W1	W2
0.85	30	20-1000	1	0.61	1400	0.18	G1/4	G1/4	19	143-14...B03	49	25	3	9	36 _{h7}	2	12.5	60	48	6.6	8 _{h5}	-	12	8.8	14	2	1/4
1.7	30	20-1000	2	0.61	2800	0.37	G1/4	G1/4	19	143-14...D03	49	25	3	9	36 _{h7}	2	12.5	60	48	6.6	8 _{h5}	-	12	8.8	14	2	1/4
2.5	20	20-1000	3	1.79	1400	0.25	G3/8	G3/8	23	143-14...F02	62	28	3	12	45 _{h7}	4	17	74	56	6.6	12 _{g5}	12 _{g5}	12	13.5	18.5	2.5	2/5
2.5	50	20-1000	3	1.79	1400	0.55	G3/8	G3/8	23	143-14...F05	62	28	3	12	45 _{h7}	4	17	74	56	6.6	12 _{g5}	12 _{g5}	12	13.5	18.5	2.5	2/5
5.25	20	20-1000	4	3.75	1400	0.55	G1/2	G1/2	27	143-14...H02	69	30	3	12.7	56 _{h7}	5	18.5	88	70	6.6	14 _{g5}	14 _{g5}	14.5	16	20.5	2.5	3/5
5.25	50	20-1000	4	3.75	1400	1.1	G1/2	G1/2	27	143-14...H05	69	30	3	12.7	56 _{h7}	5	18.5	88	70	6.6	14 _{g5}	14 _{g5}	14.5	16	20.5	2.5	3/5
9	20	20-1000	5	6.44	1400	0.75	G1/2	G1/2	27	143-14...K02	77	30	3	12.7	56 _{h7}	5	20	88	70	6.6	14 _{g5}	14 _{g5}	14.5	16	20.5	2.5	3/5
9	50	20-1000	5	6.44	1400	1.1	G1/2	G1/2	27	143-14...K05	77	30	3	12.7	56 _{h7}	5	20	88	70	6.6	14 _{g5}	14 _{g5}	14.5	16	20.5	2.5	3/5
12.5	20	20-1000	6	8.93	1400	0.75	G3/4	G3/4	33	143-14...M02	89	30	3	12.7	56 _{h7}	5	22	88	70	6.6	14 _{g5}	14 _{g5}	16	16	20.5	2.5	3/5
12.5	50	20-1000	6	8.93	1400	1.5	G3/4	G3/4	33	143-14...M05	89	30	3	12.7	56 _{h7}	5	22	88	70	6.6	14 _{g5}	14 _{g5}	16	16	20.5	2.5	3/5
19	20	20-1000	7	13.6	1400	1.5	G1	G1	40	143-14...P02	100	30	3	21.5	56 _{h7}	5	25	98	80	8.5	16 _{g5}	16 _{g5}	18	18	21.5	2.5	3/5
30	20	20-1000	8	10.74	2800	3	G1	G1	41	143-14...R02	108	42	4	23.5	80 _{f7}	6	30	119	104	8.5	19 _{g6}	22	18.5	21.5	36.5	-	3/6
30	30	20-750	8	10.74	2800	3	G1	G1	41	143-14...R03	108	42	4	23.5	80 _{f7}	6	30	119	104	8.5	19 _{g6}	22	18.5	21.5	36.5	-	3/6
30	30	20-1000	8	10.74	2800	4	G1	G1	41	143-14...R03	108	42	4	23.5	80 _{f7}	6	30	119	104	8.5	19 _{g6}	22	18.5	21.5	36.5	-	3/6
40	20	20-750	9	14.36	2800	3	G1	G1	41	143-14...T02	108	42	4	23.5	80 _{f7}	6	30	119	104	8.5	19 _{g6}	22	18.5	21.5	36.5	-	3/6
40	30	20-1000	9	14.36	2800	4	G1	G1	41	143-14...T03	108	42	4	23.5	80 _{f7}	6	30	119	104	8.5	19 _{g6}	22	18.5	21.5	36.5	-	3/6
50	20	20-1000	10	17.87	2800	4	G1 1/4	G1	41	143-14...V02	111	42	4	23.5	80 _{f7}	6	30	119	104	8.5	19 _{g6}	22	18.5 20.5	21.5	36.5	-	3/6
50	30	20-750	10	17.87	2800	4	G1 1/4	G1	41 51	143-14...V03	111	42	4	23.5	80 _{f7}	6	30	119	104	8.5	19 _{g6}	22	18.5 20.5	21.5	36.5	-	3/6
50	30	20-1000	10	17.87	2800	5.5	G1 1/4	G1	41 51	143-14...V03	111	42	4	23.5	80 _{f7}	6	30	119	104	8.5	19 _{g6}	22	18.5 20.5	21.5	36.5	-	3/6

²⁾ See P2 / S2 for thread depth for intake port S or pressure port P.

Gerotor pumps, product series 143

Gerotor pump+pump flange+shaft coupling design, technical data and dimensions

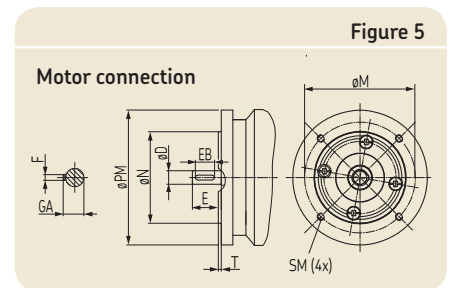
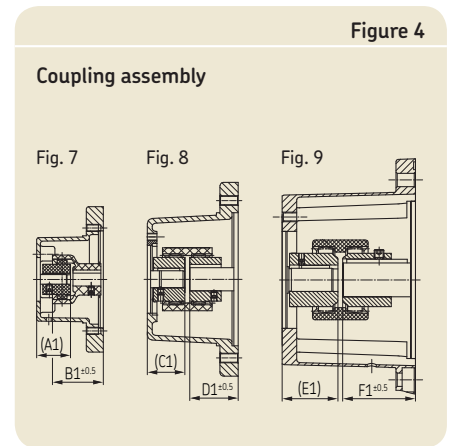
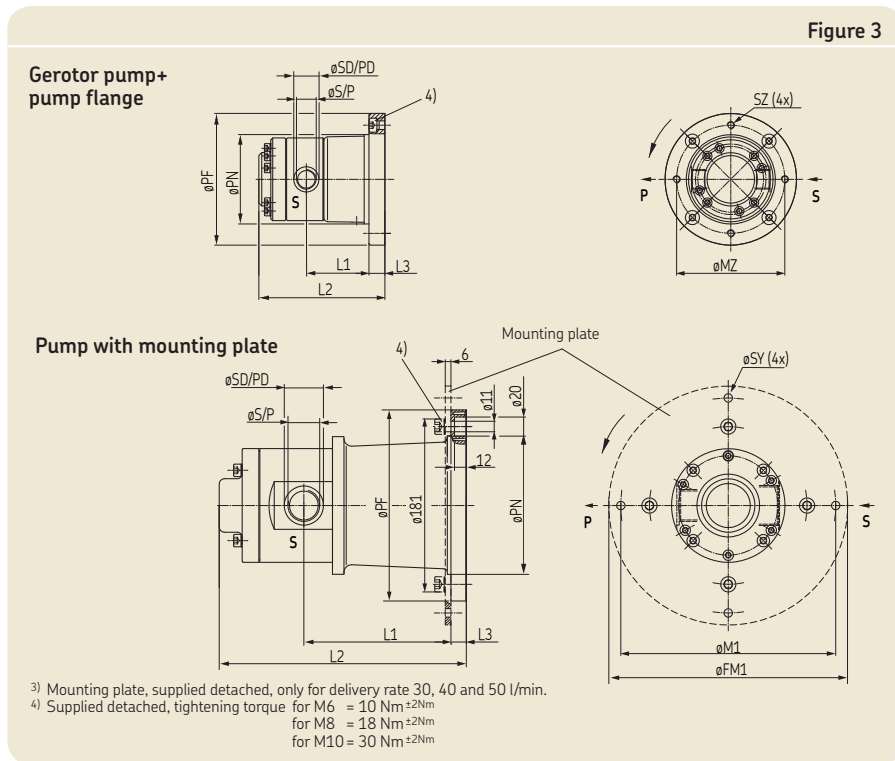

Table 1

Design N (NBR)/ F (FKM / FPM) Order No. ⁵⁾	Gerotor pump+pump flange (→ Fig. 3)					Coupling assembly (→ Fig. 4)					Motor connection (→ Fig. 5)														
	Dimensions [mm]					Dimensions [mm]					Dimensions [mm]														
	ϕPF	ϕPN	L1	L2	L3	$\phi FM1$	$\phi M1$	ϕSY	ϕMZ	SZ	Fig. 7	Fig. 8	Fig. 9	Size	ϕN	T	ϕM	SM	ϕD	E	EB	GA	F		
143-13...B03C	120	72	53.5	104	14	-	-	-	85	M6	28	42	-	-	-	63	80	3	100	M6 _{8 deep}	11 ₆	23	18	12.5	4
143-13...D03E	140	95	55.5	109	12	-	-	-	115	M8	28	42	-	-	-	71	95	3	115	M8 _{12 deep}	14 ₆	30	25	16	5
143-13...F02D	140	95	65	127	17	-	-	-	115	M8	31	51	-	-	-	71	95	3	115	M8 _{12 deep}	14 ₆	30	25	16	5
143-13...F05F	160	110	77	137	15	-	-	-	130	M8	-	-	31	40	-	80	110	3.5	130	M8 _{12 deep}	19 ₆	40	32	21.5	6
143-13...H02F	160	110	78.5	144	15	-	-	-	130	M8	-	-	31	40	-	80	110	3.5	130	M8 _{12 deep}	19 ₆	40	32	21.5	6
143-13...H05J	160	110	85.5	153	17	-	-	-	130	M8	-	-	31	49	-	90	110	3.5	130	M8 _{13 deep}	24 ₆	50	40	27	8
143-13...K02H	160	110	80	152	15	-	-	-	130	M8	-	-	31	40	-	80	110	3.5	130	M8 _{12 deep}	19 ₆	40	32	21.5	6
143-13...K05J	160	110	87	161	17	-	-	-	130	M8	-	-	31	49	-	90	110	3.5	130	M8 _{13 deep}	24 ₆	50	40	27	8
143-13...M02H	160	110	82	164	15	-	-	-	130	M8	-	-	31	40	-	80	110	3.5	130	M8 _{12 deep}	19 ₆	40	32	21.5	6
143-13...M05K	160	110	89	173	17	-	-	-	130	M8	-	-	31	49	-	90	110	3.5	130	M8 _{13 deep}	24 ₆	50	40	27	8
143-13...P02K	160	110	92	184	17	-	-	-	130	M8	-	-	30	50	-	90	110	3.5	130	M8 _{13 deep}	24 ₆	50	40	27	8
143-13...R02M	200	144.6	124	218	16	250	225	9	165	-	-	-	-	46	60	100	130	3.5	165	M10 _{12 deep}	28 ₆	60	50	31	8
143-13...R03M	200	144.6	124	218	16	250	225	9	165	-	-	-	-	46	60	100	130	3.5	165	M10 _{12 deep}	28 ₆	60	50	31	8
143-13...R03N	200	144.6	124	218	16	250	225	9	165	-	-	-	-	46	60	100	130	3.5	165	M10 _{12 deep}	28 ₆	60	50	31	8
143-13...T02M	200	144.6	124	218	16	250	225	9	165	-	-	-	-	46	60	100	130	3.5	165	M10 _{12 deep}	28 ₆	60	50	31	8
143-13...T03N	200	144.6	124	218	16	250	225	9	165	-	-	-	-	46	60	100	130	3.5	165	M10 _{12 deep}	28 ₆	60	50	31	8
143-13...V02N	200	144.6	124	221	16	250	225	9	165	-	-	-	-	46	60	112	130	3.5	165	M10 _{12 deep}	28 ₆	60	50	31	8
143-13...V03N	200	144.6	124	221	16	250	225	9	165	-	-	-	-	46	60	112	130	3.5	165	M10 _{12 deep}	28 ₆	60	50	31	8
143-13...V03P	200	145	154	251	16	250	225	9	165	-	-	-	-	48	88	132	130	3.5	165	M10 _{12 deep}	38 ₆	80	70	41	10

⁵⁾ Supplement the order No. with the code letter for the desired seal design. Seal design NBR (N) or FKM (FPM) (F).

Gerotor pumps, product series 143

Foot and flange designs, technical data and dimensions

Figure 6

Foot design (type IM B34)

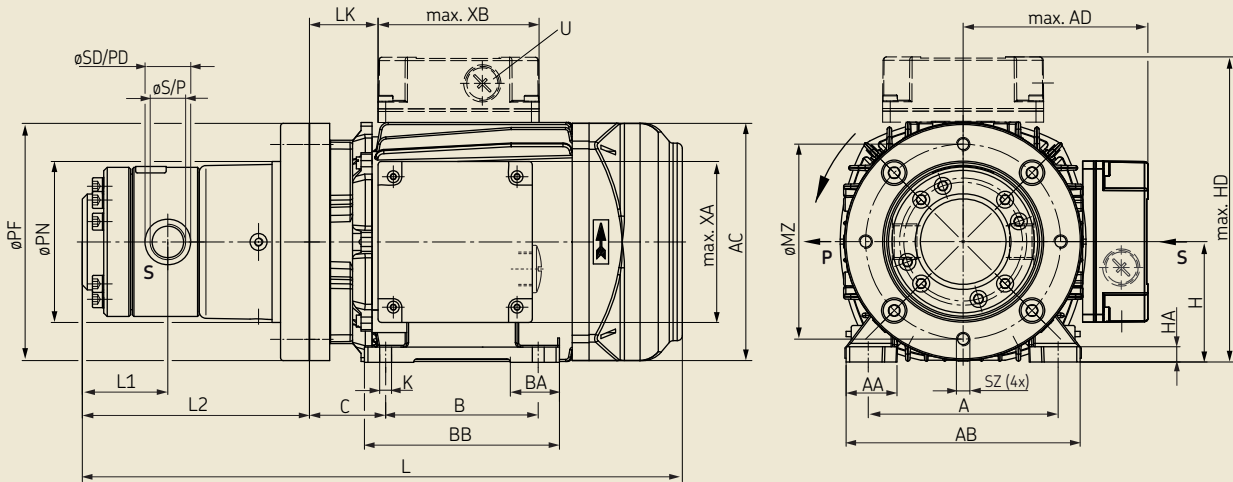

Nom. dev. rate [l/min]	Back press., max. [bar]	Permis. oper. viscosity range [mm ² /s]	Char. curve No.	Foot design N (NBR) F (FKM (FPM)) Order No. ¹⁾²⁾	Flange design N (NBR) F (FKM (FPM)) Order No. ¹⁾²⁾	Nominal output [cm ³ /rev.]	Intake port S	Pressure port P	Dimensions [mm] (→ Fig. 6+7)					
									ϕ_{PD}	ϕ_{PN}	ϕ_{PF}	ϕ_{FM1}	ϕ_{MZ}	ϕ_{M1}
0.85	30	20-1000	1	143-11...B03C-R...	143-12...B03C-X...	0.61	G1/4 ₁₂ deep	G1/4 ₁₂ deep	19	72	120	-	100	-
1.7	30	20-1000	2	143-11...D03E-R...	143-12...D03E-X...	0.61	G1/4 ₁₂ deep	G1/4 ₁₂ deep	19	95	140	-	115	-
2.5	20	20-1000	3	143-11...F02D-R...	143-12...F02D-X...	1.79	G3/8 ₁₂ deep	G3/8 ₁₂ deep	23	95	140	-	115	-
2.5	50	20-1000	3	143-11...F05F-R...	143-12...F05F-X...	1.79	G3/8 ₁₂ deep	G3/8 ₁₂ deep	23	110	160	-	130	-
5.25	20	20-1000	4	143-11...H02F-R...	143-12...H02F-X...	3.75	G1/2 _{14.5} deep	G1/2 _{14.5} deep	27	110	160	-	130	-
5.25	50	20-1000	4	143-11...H05J-O...	143-12...H05J-X...	3.75	G1/2 _{14.5} deep	G1/2 _{14.5} deep	27	110	160	-	130	-
9	20	20-1000	5	143-11...K02H-R...	143-12...K02H-X...	6.44	G1/2 _{14.5} deep	G1/2 _{14.5} deep	27	110	160	-	130	-
9	50	20-1000	5	143-11...K05J-O...	143-12...K05J-X...	6.44	G1/2 _{14.5} deep	G1/2 _{14.5} deep	27	110	160	-	130	-
12.5	20	20-1000	6	143-11...M02H-R...	143-12...M02H-X...	8.93	G3/4 ₁₆ deep	G3/4 ₁₆ deep	33	110	160	-	130	-
12.5	50	20-1000	6	143-11...M05K-O...	143-12...M05K-X...	8.93	G3/4 ₁₆ deep	G3/4 ₁₆ deep	33	110	160	-	130	-
19	20	20-1000	7	143-11...P02K-O...	143-12...P02K-X...	13.6	G1 ₁₈ deep	G1 ₁₈ deep	40	110	160	-	130	-
30	20	20-1000	8	143-11...R02M-R...	143-12...R02M-X...	10.74	G1 _{18.5} deep	G1 _{18.5} deep	41	144.6	200	250	165	225
30	30	20-750	8	143-11...R03M-R...	143-12...R03M-X...	10.74	G1 _{18.5} deep	G1 _{18.5} deep	41	144.6	200	250	165	225
30	30	20-1000	8	143-11...R03N-O...	143-12...R03N-X...	10.74	G1 _{18.5} deep	G1 _{18.5} deep	41	144.6	200	250	165	225
40	20	20-750	9	143-11...T02M-R...	143-12...T02M-X...	14.36	G1 _{18.5} deep	G1 _{18.5} deep	41	144.6	200	250	165	225
40	30	20-1000	9	143-11...T03N-O...	143-12...T03N-X...	14.36	G1 _{18.5} deep	G1 _{18.5} deep	41	144.6	200	250	165	225
50	20	20-1000	10	143-11...V02N-O...	143-12...V02N-X...	17.87	G1 1/4 _{20.5} deep	G1 _{18.5} deep	41	144.6	200	250	165	225
50	30	20-750	10	143-11...V03N-O...	143-12...V03N-X...	17.87	G1 1/4 _{20.5} deep	G1 _{18.5} deep	41	144.6	200	250	165	225
50	30	20-1000	10	143-11...V03P-R...	143-12...V03P-X...	17.87	G1 1/4 _{20.5} deep	G1 _{18.5} deep	41 51	145	200	250	165	225

¹⁾ Supplement the order No. with the code letter for the desired seal design. Seal design NBR (N) or FKM (FPM) (F).

²⁾ Supplement the order No. with the code letter for the desired motor certification (see Page 7) and the voltage code (see Page 16).

³⁾ Only standard terminal box position on top is supported; right position is not possible.

For associated motor data, see Page 17.

Gerotor pumps, product series 143

Foot and flange designs, technical data and dimensions

Figure 7

Flange design (type IM B14)

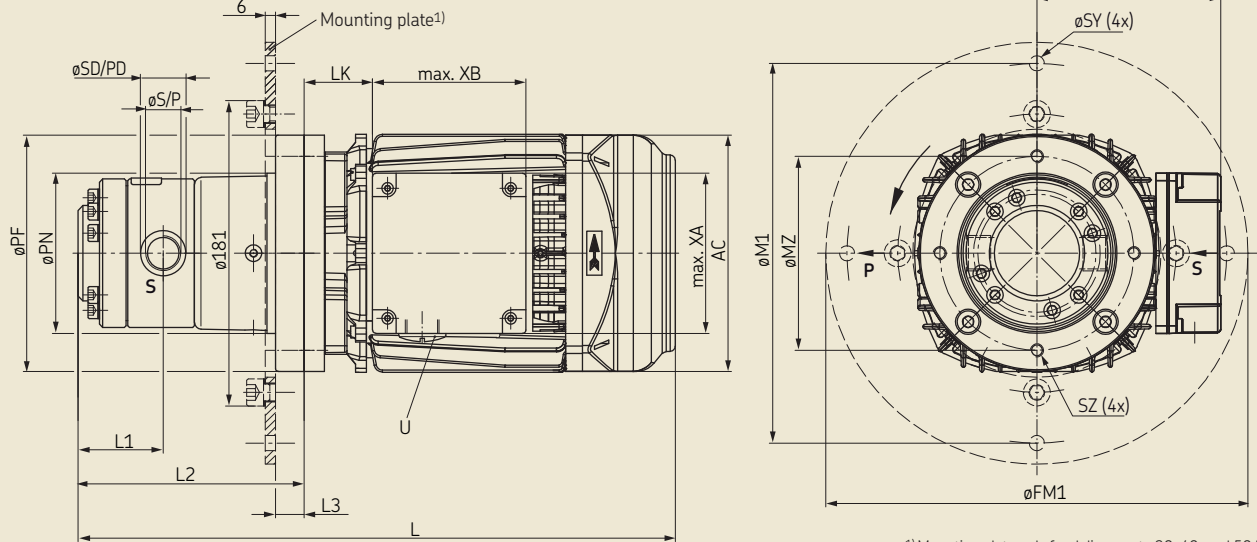

¹⁾ Mounting plate only for delivery rate 30, 40, and 50 l/min.

Table 2

Dimensions [mm] (→ Fig. 6+7)

SZ	øSY	L1	L2	L3	A	AA	AB	AC	AD _{max.}	B	BA	BB	C	H	HA	HD _{max.} ³⁾	K	U	XA _{max.}	XB _{max.}	LK	L
M6	-	36.5	104	14	100	29.5	124.5	124	122.5	80	25	100	40	63	8	-	7	1x M20x1.5	100	116	19.5	289
M8	-	36.5	109	12	112	30	138	141	109.5	90	29	115	45	71	9	-	7	1x M20x1.5	95	95	40.5	329
M8	-	45	127	17	112	30	138	141	109.5	90	29	115	45	71	9	-	7	1x M20x1.5	95	95	40.5	347
M8	-	45	137	15	125	33.5	153	159	118.5	100	32	125	50	80	10	-	10	1x M20x1.5	95	95	43.5	392
M8	-	50.5	144	15	125	33.5	153	159	118.5	100	32	125	50	80	10	-	10	1x M20x1.5	95	95	43.5	399
M8	-	50.5	153	17	140	35	170	176	118.5	125	33.5	155	56	90	11	240	10	1x M20x1.5	100	116	31	432.5
M8	-	57	152	15	125	33.5	153	159	118.5	100	32	125	50	80	10	-	10	1x M20x1.5	95	95	43.5	407
M8	-	57	161	17	140	35	170	176	118.5	125	33.5	155	56	90	11	240	10	1x M20x1.5	100	116	31	440.5
M8	-	67	164	15	125	33.5	153	159	118.5	100	32	125	50	80	10	-	10	1x M20x1.5	95	95	43.5	419
M8	-	67	173	17	140	35	170	176	148.5	125	33.5	155	56	90	11	240	10	1x M20x1.5	100	116	31	452.5
M8	-	75	184	17	140	35	170	176	148.5	125	33.5	155	56	90	11	240	10	1x M20x1.5	100	116	31	463.5
ø11	9	78	218	16	160	38	195	196	155	140	43	176	63	100	13	-	12	2x M25x1.5	100	116	116	521
ø11	9	78	218	16	160	38	195	196	155	140	43	176	63	100	13	-	12	2x M25x1.5	100	116	116	521
ø11	9	78	218	16	190	44	225	220	168	140	45	176	70	112	15	280	12	2x M25x1.5	100	116	52	538
ø11	9	78	218	16	160	38	195	196	155	140	43	176	63	100	13	-	12	2x M25x1.5	100	116	116	521
ø11	9	78	218	16	190	44	225	220	168	140	45	176	70	112	15	280	12	2x M25x1.5	100	116	52	538
ø11	9	81	221	16	190	44	225	220	168	140	45	176	70	112	15	280	12	2x M25x1.5	100	116	52	541
ø11	9	81	221	16	190	44	225	220	168	140	45	176	70	112	15	280	12	2x M25x1.5	100	116	52	541
ø11	9	81	251	16	216	55	256	246	188	140	88	218	89	132	18	-	12	2x M32x1.5	117	142	183	656

Gerotor pumps, product series 143

Characteristic curves

Chart 1

Operating viscosity 20 mm²/s, 50 Hz

Delivery rate Q [l/min]

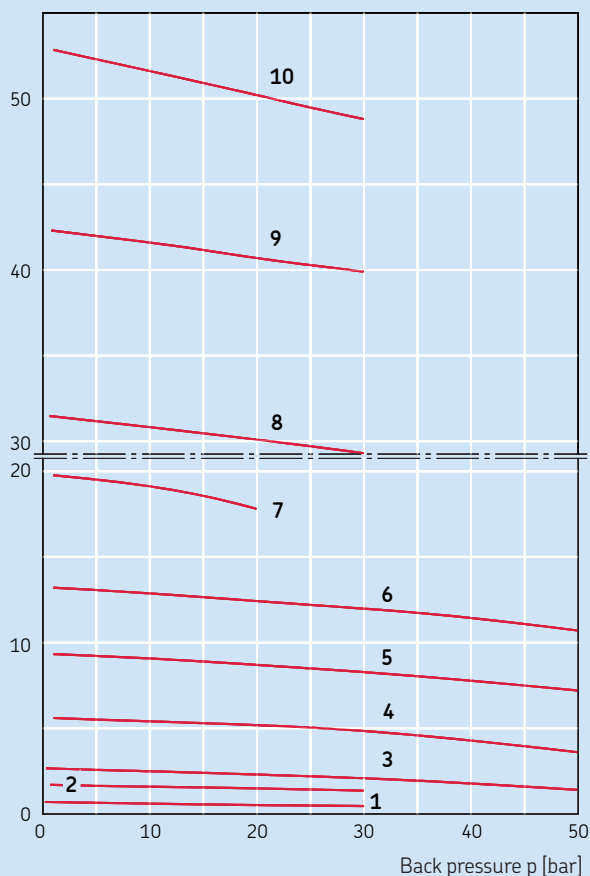
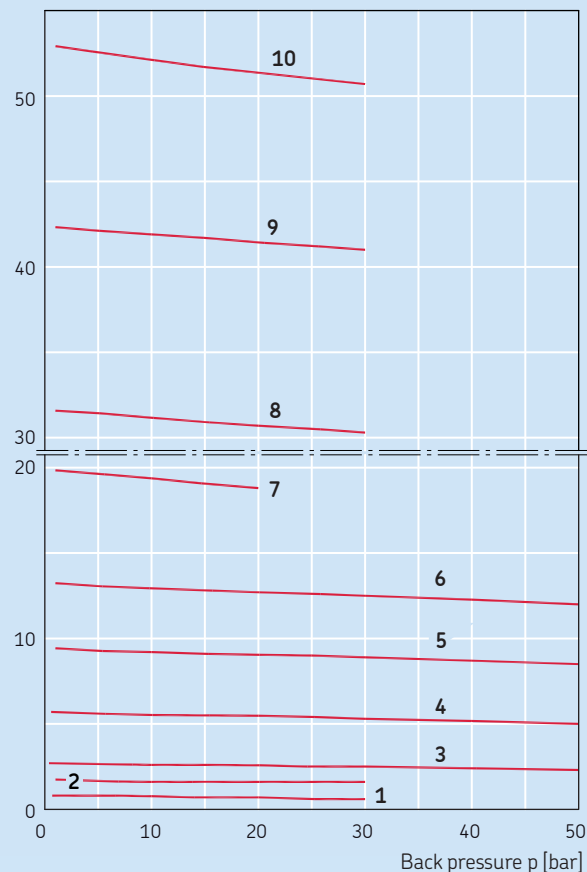

Chart 2

Operating viscosity 140 mm²/s, 50 Hz

Delivery rate Q [l/min]



Legend to diagrams 1-2:

- Characteristic curve 1: 0.85 l/min
- Characteristic curve 2: 1.7 l/min
- Characteristic curve 3: 2.5 l/min
- Characteristic curve 4: 5.25 l/min
- Characteristic curve 5: 9 l/min
- Characteristic curve 6: 12.5 l/min
- Characteristic curve 7: 19 l/min
- Characteristic curve 8: 30 l/min
- Characteristic curve 9: 40 l/min
- Characteristic curve 10: 50 l/min

Tolerances: VDMA 24284-II

For connection with a frequency of 60 Hz, the speed and the volumetric flow are increased by 20% (compared to the table specifications, basis 50 Hz).

Gerotor pumps, product series 143

Characteristic curves

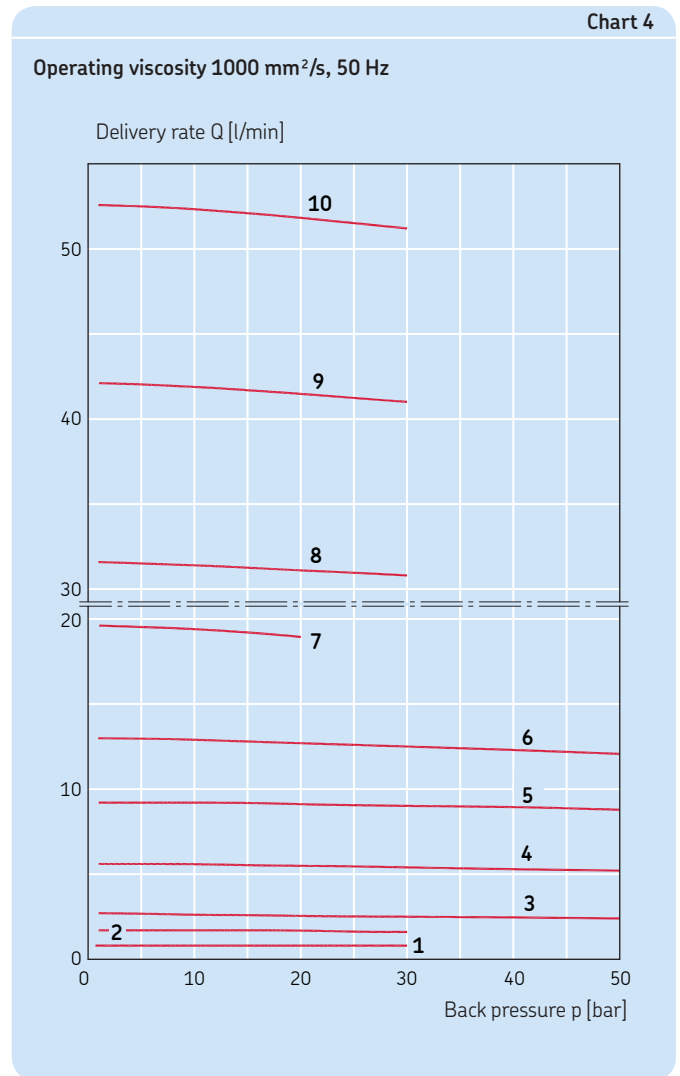
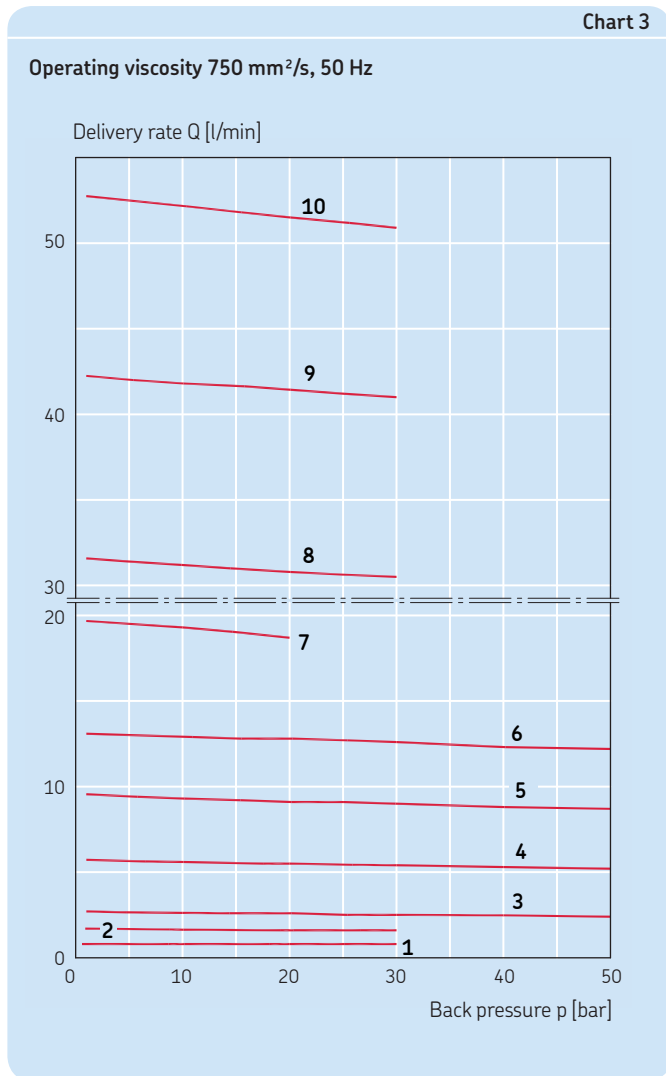

Legend to diagrams 3-4:

- Characteristic curve 1: 0.85 l/min
- Characteristic curve 2: 1.7 l/min
- Characteristic curve 3: 2.5 l/min
- Characteristic curve 4: 5.25 l/min
- Characteristic curve 5: 9 l/min
- Characteristic curve 6: 12.5 l/min
- Characteristic curve 7: 19 l/min
- Characteristic curve 8: 30 l/min
- Characteristic curve 9: 40 l/min
- Characteristic curve 10: 50 l/min

Tolerances: VDMA 24284-II

For connection with a frequency of 60 Hz, the speed and the volumetric flow are increased by 20% (compared to the table specifications, basis 50 Hz).

IEC squirrel cage motors

Fundamentals

General information

The standard design of SKF gerotor pump units of product series 143 is driven by IEC squirrel cage motors from the motor manufacturer ATB. The motors are used in sizes 63 to 132, in 2-pole and 4-pole designs. They meet the relevant IEC/EN standards both mechanically and electrically. The standard design of the motors comes with a terminal box. The motors bear a CE marking in accordance with Low Voltage Directive 2006/95/EC. There is no CE marking with respect to Machinery Directive 2006/42/EC and EMC Directive 2004/108/EC because three-phase motors do not fall under the scope of these Directives.

Special provisions

The motors can be ordered in a UL- and CSA-compliant design and are approved as a "recognized component" by UL (Underwriter Laboratories). These motors have an electrical design according to NEMA MG1-12.

CSA BG56-80 File No.: LR 88093
(listed under Master Contract No. 150227)

CSA BG90-132 File No.: LR 12638
(listed under Master Contract No. 150227)

UL BG56-80 File No.: E123665
(combined acceptance per UL 1004 and CSA 22.2.100)

UL BG90-132 File No.: E125750
(combined acceptance per UL 1004 and CSA 22.2.100)

Further certifications are available on request

Types

The motors are used exclusively in the types IM B34 and IM B14. The type is indicated according to Code I, DIN EN 60034-7 on the rating plate.

IM B34: Shaft horizontal, feet on floor

IM B14: Shaft horizontal, no feet

Rated voltage, frequency, and power

The motors are designed standard for a rated motor voltage of 230 V, 400 V, or 690 V for 50 Hz networks (normal coils) according to DIN IEC 60038. Motors for other voltages and frequencies (special coils) are available at extra charge.

The permissible operating voltage deviation in the specified rated motor voltages and special voltages per DIN EN 60034-1 is $\pm 10\%$ and the permissible frequency deviation is $-5/+3\%$.

The tolerances according to DIN EN 60034-1 are maintained at supply voltages on the order of 95% or 105% of the rated motor voltage. Further, motor heating may exceed the permissible temperature limit by 10 K. Higher heating is permissible, though continuous operation (duty) of the motors at higher temperature values is not recommended.

Motors for a rated motor voltage of 230 V or 400 V for 50 Hz networks (normal coil) and with performance < 0.75 kW are designed for the wide voltage range for 50 and 60 Hz networks. The motors can be used in continuous duty (S1) within this wide voltage range. The wide voltage range is indicated on the motor's rating plate.

Wide voltage range:

50 Hz: 220–240 V / 380–420 V,
voltage tolerance $\pm 5\%$

60 Hz: 254–280 V / 440–480 V,
voltage tolerance $\pm 5\%$

The use of the wide voltage range is permitted because these motors are not subject to EU Directive 2005/32/EC (Energy Using Products) and therefore do not need to comply with EU Regulation No. 640/2009 with regard to adherence to efficiency classes. These motors do not bear an IE2 marking on the rating plate.

Motors for special voltages with performance < 0.75 kW contain special coils that are designed for one voltage/frequency point (such motors are also referred to as tailor-made motors). Special voltage designs for 50 and 60 Hz networks are available at extra charge and must be indicated when ordering.

Motors with performance ≥ 0.75 kW are optimized for one voltage/frequency point and are designed solely on a tailor-made basis. They are designed standard for a rated motor voltage of 230 V, 400 V, or 690 V for 50 Hz networks (normal coils) according to DIN IEC 60038. They meet efficiency class IE2 according to EU Directive 2005/32/EC (Energy Using Products). These motors bear an IE2 marking on the rating plate.

Motors for special voltages with performance < 0.75 kW contain special coils that are designed for one voltage/frequency point. Special voltage designs for 50 and 60 Hz networks are available for all rated motor voltages commonly used worldwide and must be indicated when ordering.

The stated performance ratings and operating values are valid for duty type S1 according to DIN EN 60034-1 at the indicated rated frequency, rated voltage, a coolant temperature of max. 40 °C, and a site altitude of up to 1000 m above sea level. Motors for operating conditions other than those indicated can be requested at extra charge.

Circuit

The phase belts of the motor that are laid on the terminal board can be interconnected in two different connection systems.

Star connection

In the star connection, the coil ends U2, V2, and W2 are interconnected on the terminal board, creating the neutral point. Mains power is connected on the free connection ports of the coil ends U1, V1, and W1 on the terminal board.

Delta connection

In the delta connection, the end of the phase belt is interconnected with the beginning of the next phase belt. (U2 to V1, V2 to W1, W2 to U1). Mains power is connected at the connection points on the terminal board.

IEC squirrel cage motors

Cooling method

The motors are designed for cooling method IC 411 (surface cooling).

Temperature class

The insulation on the motor coils is designed for temperature class 155 (F). When utilized at their performance rating,

the motors meet temperature class 130 (B). Given a coolant temperature of 40°C, the power reserve is thus approx. +10%; when operated at their performance rating, the temperature reserve is approx. +20 K.

Rating plates according to DIN EN 60034-1

Europe (CE) without IE2

Wide voltage range

AF 63/4B-7 /0805		3~ Mot 63	H 0001
YΔ 400/230 V	0,69/1,04 A	0,18 kW	361079
cos φ 0,69	1360 1/min	50 Hz	
Th.Cl. 155 (F) IP55 IMB34 EN 60034		4,4 kg	
YΔ 380-420/220-240 V	0,63/1,09 A	0,18 kW	
cos φ 0,69	1380 1/min	50 Hz	
YΔ 440-480/254-280 V	0,60/1,04 A	0,215 kW	
cos φ 0,69	1675 1/min	60 Hz	CE

Tailor-made

LF 71/2A-11 /0805		3~ Mot 71	H 0001
YΔ 500/290 V	0,76/1,32 A	0,37 kW	575540
cos φ 0,81	2860 1/min	50 Hz	
Th.Cl. 155 (F) IP55 IMB34 EN 60034			
YΔ 575/330 V	0,73/1,26 A	0,45 kW	
cos φ 0,83	3440 1/min	60 Hz	CE

USA / Canada (UL/CSA) without IE2

Wide voltage range

AF 63/4B-11 /0805		AC 3 Phase-Motor	H 0001
Serie 63	571730		
YΔ 400/230 V	0,60/1,05 A	0,18 kW	
50 Hz		1380 rpm	cos φ 0,71
0,24 HP		AMB TEMP 40 °C	TEFC EN 60034
YΔ 440-480/254-280 V	0,30 HP	0,60/1,04 A	
cos φ 0,72	60 Hz	0,22 kW	1675 rpm
4,40 kg	Class 155 (F)	IP55	DutyCycle 51

Tailor-made

LF 71/2A-11 /0805		AC 3 Phase-Motor	H 0001
Serie 71	xxxx		
YΔ V	500/290 V	0,37 kW	
50 Hz	A	2860 rpm	cos φ 0,81
0,50 HP		AMB TEMP 40 °C	TEFC EN 60034
YΔ 575/330 V	0,73/1,26 A	0,45 kW	
cos φ 0,83	60 Hz	0,45 kW	3440 rpm
xxx kg	Class 155 (F)	IP55	DutyCycle 51

Europe (CE) and USA / Canada (UL/CSA) with IE2¹⁾

Tailor-made

AF 90 L/4M-13L+E2 /0805		CE	
S1	IMB34	-0001	571260 H
IP55		Th.Cl. 155 (F)	
AMB TEMP 40 °C			
kW	V	Hz	A
1,50	YΔ400/230	50	3,30/5,70
			0,79
			1440
1,80	YΔ460/265	60	3,30/5,70
			0,81
			1730
+/-10%			
IE75%/50%		81,3/78,7 18,6kg EN60034	
IE2			

Tailor-made

AF 90 L/4M-13L+E2 /0805		UL/CSA	
Serie90	TEFC	-0001	571260 H
IP55		Class 155 (F)	
AMB TEMP 40 °C			
kW	V	Hz	A
1,50	YΔ400/230	50	3,30/5,70
			0,79
			1440
1,80	YΔ460/265	60	3,30/5,70
			0,81
			1730
+/-10%			
IE75%/50%		18,6kg	

- | | | |
|-----------------------|------------------|----------------------------|
| 1 Size | 7 Rated speed | 11 Rated operating voltage |
| 2 Protection class | 8 Data for 50 Hz | 12 Efficiency |
| 3 Temperature class | 9 Data for 60 Hz | (only IE2 motors) |
| 4 Type | 10 Certification | |
| 5 Rated voltage range | | |
| 6 Rated current | | |

¹⁾In the UL/CSA design, the motor is also supplied with a rating place for CE.

Terminal box

The terminal boxes have a protection class of IP55. The terminal box is positioned on the right when viewed from the drive side. An exception is 4-pole motors of size 90 (1.1 and 1.5 kW), in which the terminal box is installed on the top for design reasons. Special motors with the terminal box positioned on the left as viewed from the drive side are available on request.

The position of the openings for cable entry can be adjusted to the available connections by turning the terminal box by 90° each time (terminal box design 95×95 mm). Terminal boxes with dimensions 120×115 mm can only be turned by 180°. The threads on the cable inlets have a metric thread of M20x1.5. The terminal board has a 6-pole design.

Protection class

The motors are designed for protection class IP55 according to DIN EN 60034-5.

Touch and foreign object protection: Provides complete protection against contacting or getting close to such parts, as well as against touching moving parts within the housing. Provides protection against the ingress of damaging amounts of dust deposits.

Water protection:

A jet of water from a nozzle and aimed at the motor from all directions has no adverse effect.

IEC squirrel cage motors

Voltage code

Table 3

Voltages and frequencies of different countries

	Voltage [V]	Voltage tolerance [%]	Design with terminal box				Country code
			Without IE2 (P <0.75 kW)		With IE2 (P ≥0.75 kW)		
			CE	UL/CSA	CE	UL/CSA	
50 Hz	200 / 345	±10	+1GF	+1GF	+1GF	+1GF	JP, HK
	220 / 380	±5	+1FX	+1HM	–	–	CN, RU, TR, IQ, IR, ID, IN, TH, VN, AR, CL
	220 / 380	±10	+1GP	+1GP	+1GP	+1GP	CN, RU, TR, IQ, IR, ID, IN, TH, VN, AR, CL
	230 / 400	±10	+1FX	+1HM	+1GD	+1GD	EU, IL, NZ, PK, ZA, AE
	240 / 415	±5	+1FX	+1HM	–	–	UK, IN, IQ, MY, AU, SG
	240 / 415	±10	+1GQ	+1GQ	+1GQ	+1GQ	UK, IN, IQ, MY, AU, SG
	255 / 440	±10	+MFN	+MFN	+MFN	+MFN	
	290 / 500	±10	+1HQ	+1HQ	+1HQ	+1HQ	
	305 / 525	±10	+MMP	–	+MMP	–	ZA
	380 / 660	±10	–	–	+1GH ¹⁾	–	CN, RU, TR, IQ, IR, ID, IN, TH, VN, AR, CL
	400 / 690	±10	–	–	+1GK ¹⁾	–	EU, IL, NZ, PK, ZA, AE
415 / 720	±10	–	–	+1GL ¹⁾	–	UK, IN, IQ, MY, AU, SG, AE	
60 Hz	200 / 345	±10	+1GG	+1GG	+1GG	+1GG	JP
	220 / 380	±10	+MDP	+MDP	+MDP	+MDP	BR, KR, PE, MX, SA, TW, VE, BO
	230 / 400	±10	+1GR	+1GR	+1GR	+1GR	
	255 / 440	±5	+1FX	+1HM	–	–	PA, MX, PH
	255 / 440	±10	+1GP	+1GP	+1GP	+1GP	PA, MX, PH
	400	±10	–	–	+1GH ¹⁾	–	PA, MX, PH
	265 / 460	±10	+1FX	+1HM	+1GD	+1GD	US, CA, MX
	460	±10	–	–	+1GK ¹⁾	–	US, CA, MX
	460 delta	±10	–	–	–	+1KG ²⁾	US, CA, MX
	280 / 480	±5	+1FX	+1HM	–	–	US, CN, PA
	280 / 480	±10	+1GQ	+1GQ	+1GQ	+1GQ	US, CN, PA
	480	±10	–	–	+1GL ¹⁾	–	US, CN, PA
	330 / 575	±10	+1HQ	+1HQ	+1HQ	+1HQ	CA

AE = United Arab Emirates
AR = Argentina
AU = Australia
BO = Bolivia
BR = Brazil
CA = Canada
KR = Korea
CL = Chile
CN = China

EU = Europe
HK = Hong Kong
ID = Indonesia
IL = Israel
IN = India
IQ = Iraq
IR = Iran
JP = Japan
MX = Mexico

MY = Malaysia
NZ = New Zealand
PA = Panama
PE = Peru
PH = Philippines
PK = Pakistan
SA = Saudi Arabia
SG = Singapore
RU = Russia

TW = Taiwan
TH = Thailand
TR = Turkey
UK = United Kingdom
US = USA
VE = Venezuela
VN = Vietnam
ZA = South Africa

Note: Motors with a performance rating of ≥0.75 kW must be designed for efficiency class IE2.

(others available on request)

¹⁾ P ≥5.5 kW not for UL/CSA
²⁾ P ≥5.5 kW only for UL/CSA

Voltage code texts

+1GP	220/380 V, 50 Hz; 255/440 V, 60 Hz (±10%)	+1GL	415/720 V, 50 Hz; 480 V, 60 Hz (±10%)	+MMP	305/525 V, 50 Hz (±10%)
+1GD	230/400 V, 50 Hz; 265/460 V, 60 Hz (±10%)	+1KG	400 V, 50 Hz; 460 V, 60 Hz (±10%)		220–240 V / 380–420 V, 50 Hz (±5%)
+1GQ	240/415 V, 50 Hz; 280/480 V, 60 Hz (±10%)	+1GF	220/345 V, 50 Hz (±10%)	+1FX	254–280 V / 440–480 V, 60 Hz (±5%)
+1HQ	290/500 V, 50 Hz; 330/575 V, 60 Hz (±10%)	+1GG	200/345 V, 60 Hz (±10%)	+1HM	220–240 V / 380–420 V, 50 Hz (±5%)
+1GH	380/660 V, 50 Hz; 440 V 60 Hz (±10%)	+MDP	220/380 V, 60 Hz (±10%)		254–280 V / 440–480 V, 60 Hz (±5%)
+1GK	400/690 V, 50 Hz; 460 V, 60 Hz (±10%)	+1GR	230/400 V, 60 Hz (±10%)		

IEC squirrel cage motors

Technical data

Squirrel cage motor in foot design



Technical data

Type	Foot design IM B34, Flange design IM B14
Protection class	IP55
Temperature class	155 (F) utilized according to B
Duty type	S1
Temperature range	-20 to +40 °C
Max. site altitude	1000 m above sea level
Cooling method	IC 41 (surface cooling with fan)
Temperature monitoring	none
Frequency converter operation	According to DIN IEC / TS 60034-17 (VDE 0530 Part 17) 2004, suitable for converter operation for supply voltages up to and including 480 V
Terminal box material	Metal

Table 4

Motor data

Size	Certi- fication	No. of poles	Flange- design (with threaded hole) ¹⁾	Weight [kg]	50 Hz			60 Hz				
					Rated voltage ²⁾ Δ / Y [V]	Rated power ³⁾ [kW]	Speed [rpm]	Rated current Δ / Y [A]	Rated voltage ²⁾ Δ / Y [V]	Rated power ³⁾ [kW]	Speed [rpm]	Rated current Δ / Y [A]
63	CE UL/CSA	4	FT100 (C120)	5	230 / 400	0.18	1380	1.15 / 0.65	265 / 460	0.22	1670	1.05 / 0.65
71	CE UL/CSA	2	FT115 (C140)	8	230 / 400	0.37	2880	1.86 / 1.08	265 / 460	0.44	3470	1.75 / 1.00
71	CE UL/CSA	4	FT115 (C140)	8	230 / 400	0.25	1420	0.90	265 / 460	0.30	1710	0.90
71	CE UL/CSA	4	FT115 (C140)	8	230 / 400	0.37	1430	1.80 / 1.00	265 / 460	0.44	1735	1.75 / 1.00
80	CE UL/CSA	4	FT130 (C160)	10	230 / 400	0.55	1410	2.90 / 1.70	265 / 460	0.62	1720	2.70 / 1.50
80	CE	4	FT130 (C160)	10	230 / 400	0.75	1440	2.96 / 1.71	265 / 460	0.90	1740	2.98 / 1.72
80	UL/CSA	4	FT130 (C160)	10	-	-	-	-	265 / 460	0.90	1740	2.98 / 1.72
90	CE	4	FT130 (C160)	20	230 / 400	1.10	1435	4.33 / 2.50	265 / 460	1.30	1740	4.23 / 2.44
90	UL/CSA	4	FT130 (C160)	20	-	-	-	-	265 / 460	1.30	1740	4.23 / 2.44
90	CE	4	FT130 (C160)	20	230 / 400	1.50	1440	5.70 / 3.30	265 / 460	1.80	1730	5.70 / 3.30
90	UL/CSA	4	FT130 (C160)	20	-	-	-	-	265 / 460	1.80	1730	5.70 / 3.30
100	CE	2	FT165 (C200)	25	230 / 400	3.00	2900	9.90 / 5.70	460	3.60	3485	5.80
100	UL/CSA	2	FT165 (C200)	25	-	-	-	-	460	3.60	3485	5.80
112	CE	2	FT165 (C200)	35	230 / 400	4.00	2880	12.4 / 7.15	460	4.80	3475	7.35
112	UL/CSA	2	FT165 (C200)	35	-	-	-	-	460	4.80	3475	7.35
132	CE	2	FT165 (C200)	45	400 / 690	5.50	2910	10.0 / 5.75	460	6.60	3500	10.30
132	UL/CSA	2	FT165 (C200)	45	400	5.50	2910	10.0	460	6.60	3500	10.30

¹⁾ Flange with threaded hole acc. to DIN EN 50347 (FT).

²⁾ Beyond a performance rating of 0.75 kW, the motors come with tailor-made coils. Wide voltage range motors only for performance ratings < 0.75 kW.

³⁾ Beyond a performance rating of 0.75 kW, the motors are designed for efficiency class IE2.

Viscosity-temperature relationship of oils with different rated viscosity

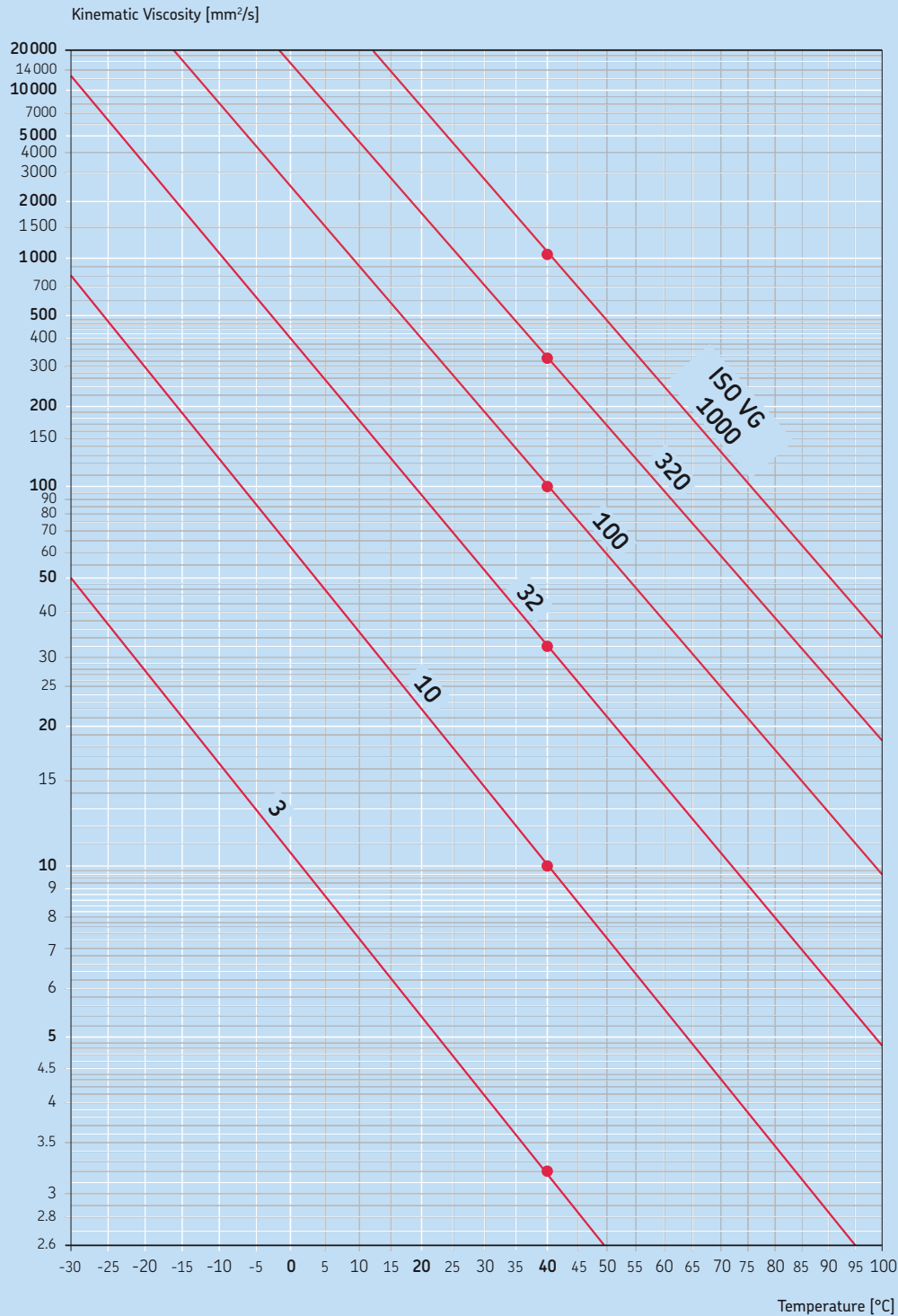

The curves are based on a viscosity index of VI - 95, approximately corresponding to standard mineral oil. The viscosity index describes the slope of the curve and thus the viscosity-temperature relationship at temperatures other than +40°C. The lines appear straight because a logarithmic scale was selected for the ordinates so that the slope of the curves can be determined easily based on 2 measuring points.

ISO VG	Viscosity class *) is approx.
3, 10	Spindle oils
32, 100	Normal machine oils
320	Medium-heavy machine oils
1000	Gear oil or similar

*) The values correspond to the midpoint viscosity at 40°C in mm²/s

Note: The change in the viscosity of oils is disproportionately greater in lower temperature ranges than in higher temperature ranges. For example, an oil with a rated viscosity of 100 undergoes the following viscosity change in different temperature ranges at the same temperature difference:

at +80 °C = 18 mm²/s
 at +75 °C = 21 mm²/s
 change of 3 mm²/s

versus

at +10 °C = 875 mm²/s
 at + 5 °C = 1450 mm²/s
 change of 575 mm²/s

Spare parts

Exploded view

Figure 8

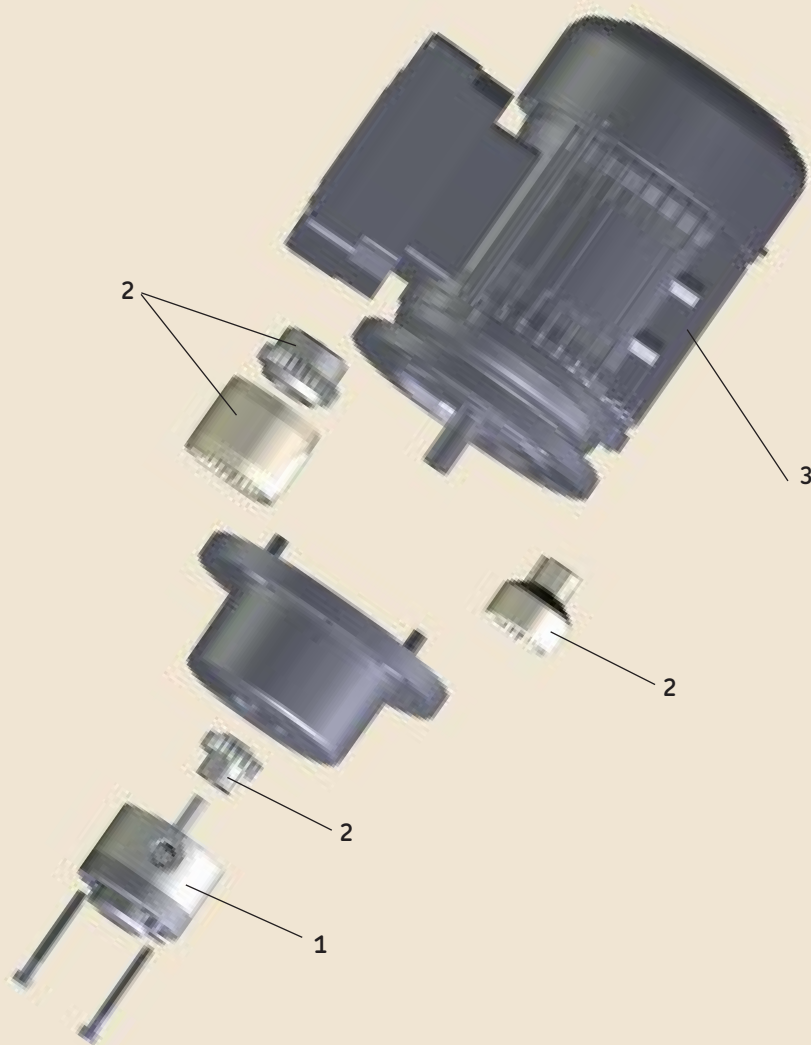

See next page for the position description.



Dismantling of the product or individual parts thereof within the statutory warranty period is not permitted and voids any warranty claims.

Spare parts

Position description (→ Fig. 8)

Gerotor pump unit ¹⁾	Pos. 1 Pump ¹⁾	Pos. 2 Coupling, complete ²⁾	Pos. 3 Motor	Description	Order No.
143-11...B03C-RA+1FX	143-14...B03	995-000-350	178-AA12C-AMRA+1FX	Doc. package	995-810-002
143-12...B03C-XA+1FX	143-14...B03	995-000-350	178-AA22C-AMXA+1FX	Rotation arrow	760-072
143-11...D03E-RA+1FX	143-14...D03	995-000-351	178-AA11E-AMRA+1FX		
143-12...D03E-XA+1FX	143-14...D03	995-000-351	178-AA21E-AMXA+1FX		
143-11...F02D-RA+1FX	143-14...F02	995-000-353	178-AA12D-AMRA+1FX		
143-12...F02D-XA+1FX	143-14...F02	995-000-353	178-AA22D-AMXA+1FX		
143-11...F05F-RA+1FX	143-14...F05	995-000-354	178-AA12F-AMRA+1FX		
143-12...F05F-XA+1FX	143-14...F05	995-000-354	178-AA22F-AMXA+1FX		
143-11...H02F-RA+1FX	143-14...H02	995-000-356	178-AA12F-AMRA+1FX		
143-12...H02F-XA+1FX	143-14...H02	995-000-356	178-AA22F-AMXA+1FX		
143-11...H05J-OA+1GD	143-14...H05	995-000-357	178-AA12J-AMOA+1GD		
143-12...H05J-XA+1GD	143-14...H05	995-000-357	178-AA22J-AMXA+1GD		
143-11...K02H-RA+1GD	143-14...K02	995-000-356	178-AA12H-AMRA+1GD		
143-12...K02H-XA+1GD	143-14...K02	995-000-356	178-AA22H-AMXA+1GD		
143-11...K05J-OA+1GD	143-14...K05	995-000-357	178-AA12J-AMOA+1GD		
143-12...K05J-XA+1GD	143-14...K05	995-000-357	178-AA22J-AMXA+1GD		
143-11...M02H-RA+1GD	143-14...M02	995-000-356	178-AA12H-AMRA+1GD		
143-12...M02H-XA+1GD	143-14...M02	995-000-356	178-AA22H-AMXA+1GD		
143-11...M05K-OA+1GD	143-14...M05	995-000-357	178-AA12K-AMOA+1GD		
143-12...M05K-XA+1GD	143-14...M05	995-000-357	178-AA22K-AMXA+1GD		
143-11...P02K-OA+1GD	143-14...P02	995-000-358	178-AA12K-AMOA+1GD		
143-12...P02K-XA+1GD	143-14...P02	995-000-358	178-AA22K-AMXA+1GD		
143-11...R02M-RA+1GD	143-14...R02	995-000-359	178-AA11M-AMRA+1GD		
143-12...R02M-XA+1GD	143-14...R02	995-000-359	178-AA21M-AMXA+1GD		
143-11...R03M-RA+1GD	143-14...R03	995-000-359	178-AA11M-AMRA+1GD		
143-12...R03M-XA+1GD	143-14...R03	995-000-359	178-AA21M-AMXA+1GD		
143-11...R03N-OA+1GD	143-14...R03	995-000-359	178-AA11N-AMOA+1GD		
143-12...R03N-XA+1GD	143-14...R03	995-000-359	178-AA21N-AMXA+1GD		
143-11...T02M-RA+1GD	143-14...T02	995-000-359	178-AA11M-AMRA+1GD		
143-12...T02M-XA+1GD	143-14...T02	995-000-359	178-AA21M-AMXA+1GD		
143-11...T03N-OA+1GD	143-14...T03	995-000-359	178-AA11N-AMOA+1GD		
143-12...T03N-XA+1GD	143-14...T03	995-000-359	178-AA21N-AMXA+1GD		
143-11...V02N-OA+1GD	143-14...V02	995-000-359	178-AA11N-AMOA+1GD		
143-12...V02N-XA+1GD	143-14...V02	995-000-359	178-AA21N-AMXA+1GD		
143-11...V03N-OA+1GD	143-14...V03	995-000-359	178-AA11N-AMOA+1GD		
143-12...V03N-XA+1GD	143-14...V03	995-000-359	178-AA21N-AMXA+1GD		
143-11...V03P-RA+1GK	143-14...V03	995-000-360	178-AA11P-AMRA+1GK		
143-12...V03P-XA+1GK	143-14...V03	995-000-360	178-AA21P-AMXA+1GK		

¹⁾ Supplement the order No. with the code letter for the desired seal. Design NBR (N) or FKM (FPM) (F).

²⁾ It is recommended that coupling parts always be replaced completely.

Gerotor pump, product series 143

Comparison of order numbers

Table 6

Comparison of old and new order Nos. for gerotor pump, product series 143

Nominal delivery rate [l/min]	Back pressure, max. [bar]	Permiss. oper. viscosity range [mm ² /s]	Seal design NBR		Seal design FKM (FPM)	
			Gerotor pump		Gerotor pump	
			Old order No.	New order No.	Old order No.	New order No.
0.85	30	20-1000	143-011-131	143-14NB03	143-011-132	143-14FB03
1.7	30	20-1000	143-011-131	143-14ND03	143-011-132	143-14FD03
2.5	20	20-1000	143-011-151 ¹⁾ / -152 ²⁾	143-14NF02 ²⁾	143-011-159 ¹⁾	143-14FF02 ²⁾
2.5	50	20-1000	143-011-151 ¹⁾ / -152 ²⁾	143-14NF05 ²⁾	143-011-159 ¹⁾	143-14FF05 ²⁾
5.25	20	20-1000	143-011-161	143-14NH02	143-011-169	143-14FH02
5.25	50	20-1000	143-011-161	143-14NH05	143-011-169	143-14FH05
9	20	20-1000	143-011-171	143-14NK02	143-011-173	143-14FK02
9	50	20-1000	143-011-171	143-14NK05	143-011-173	143-14FK05
12.5	20	20-1000	143-011-181-2	143-14NM02	143-011-187	143-14FM02
12.5	50	20-1000	143-011-181-2	143-14NM05	143-011-187	143-14FM05
19	20	20-1000	143-011-500	143-14NP02	143-011-508	143-14FP02
30	20	20-1000	-	143-14NR02	-	143-14FR02
30	30	20-750	-	143-14NR03	-	143-14FR03
30	30	20-1000	-	143-14NR03	-	143-14FR03
40	20	20-750	-	143-14NT02	-	143-14FT02
40	30	20-1000	-	143-14NT03	-	143-14FT03
50	20	20-1000	-	143-14NV02	-	143-14FV02
50	30	20-750	-	143-14NV03	-	143-14FV03
50	30	20-1000	-	143-14NV03	-	143-14FV03

¹⁾ counterclockwise
²⁾ clockwise

Gerotor pump, product series 143

Comparison of order numbers

Table 7

Comparison of old and new order Nos. for gerotor pump unit in foot design, product series 143

Nominal delivery rate [l/min]	Back press., max. [bar]	Permiss. oper. viscosity range [mm ² /s]	Foot design			
			Seal design N (NBR)		Seal design F (FKM (FPM))	
			Old order No.	New order No.	Old order No.	New order No.
0.85	30	20-1000	143-012-131+...	143-11NB03C-RA+1FX	-	143-11FB03C-RA+1FX
1.7	30	20-1000	143-012-141+...	143-11ND03E-RA+1FX	143-012-142+...	143-11FD03E-RA+1FX
2.5	20	20-1000	-	143-11NF02D-RA+1FX	-	143-11FF02D-RA+1FX
2.5	50	20-1000	-	143-11NF05F-RA+1FX	-	143-11FF05F-RA+1FX
5.25	20	20-1000	-	143-11NH02F-RA+1FX	-	143-11FH02F-RA+1FX
5.25	50	20-1000	-	143-11NH05J-OA+1GD	-	143-11FH05J-OA+1GD
9	20	20-1000	-	143-11NK02H-RA+1GD	-	143-11FK02H-RA+1GD
9	50	20-1000	143-012-171+...	143-11NK05J-OA+1GD	-	143-11FK05J-OA+1GD
12.5	20	20-1000	143-012-180+...	143-11NM02H-RA+1GD	-	143-11FM02H-RA+1GD
12.5	50	20-1000	143-012-181+...	143-11NM05K-OA+1GD	-	143-11FM05K-OA+1GD
19	20	20-1000	143-012-501+...	143-11NP02K-OA+1GD	143-012-509+...	143-11FP02K-OA+1GD
30	20	20-1000	-	143-11NR02M-RA+1GD	-	143-11FR02M-RA+1GD
30	30	20-750	-	143-11NR03M-RA+1GD	-	143-11FR03M-RA+1GD
30	30	20-1000	-	143-11NR03N-OA+1GD	-	143-11FR03N-OA+1GD
40	20	20-750	-	143-11NT02N-OA+1GD	-	143-11FT02N-OA+1GD
40	30	20-1000	-	143-11NT03N-OA+1GD	-	143-11FT03N-OA+1GD
50	20	20-1000	-	143-11NV02N-OA+1GD	-	143-11FV02N-OA+1GD
50	30	20-750	-	143-11NV03N-OA+1GD	-	143-11FV03N-OA+1GD
50	30	20-1000	-	143-11NV03P-RA+1GK	-	143-11FV03P-RA+1GK

Table 8

Comparison of old and new order Nos. for gerotor pump unit in flange design, product series 143

Nominal delivery rate [l/min]	Back press., max. [bar]	Permiss. oper. viscosity range [mm ² /s]	Flange design			
			Seal design N (NBR)		Seal design F (FKM (FPM))	
			Old order No.	New order No.	Old order No.	New order No.
0.85	30	20-1000	143-012-231+...	143-12NB03C-XA+1FX	-	143-12FB03C-XA+1FX
1.7	30	20-1000	143-012-241+...	143-12ND03E-XA+1FX	143-012-242+...	143-12FD03E-XA+1FX
2.5	20	20-1000	-	143-12NF02D-XA+1FX	-	143-12FF02D-XA+1FX
2.5	50	20-1000	-	143-12NF05F-XA+1FX	-	143-12FF05F-XA+1FX
5.25	20	20-1000	-	143-12NH02F-XA+1FX	-	143-12FH02F-XA+1FX
5.25	50	20-1000	-	143-12NH05J-XA+1GD	-	143-12FH05J-XA+1GD
9	20	20-1000	-	143-12NK02H-XA+1GD	-	143-12FK02H-XA+1GD
9	50	20-1000	143-012-271+...	143-12NK05J-XA+1GD	-	143-12FK05J-XA+1GD
12.5	20	20-1000	143-012-280+...	143-12NM02H-XA+1GD	-	143-12FM02H-XA+1GD
12.5	50	20-1000	143-012-281+...	143-12NM05K-XA+1GD	-	143-12FM05K-XA+1GD
19	20	20-1000	143-012-601+...	143-12NP02K-XA+1GD	-	143-12FP02K-XA+1GD
30	20	20-1000	-	143-12NR02M-XA+1GD	-	143-12FR02M-XA+1GD
30	30	20-750	-	143-12NR03M-XA+1GD	-	143-12FR03M-XA+1GD
30	30	20-1000	-	143-12NR03N-XA+1GD	-	143-12FR03N-XA+1GD
40	20	20-750	-	143-12NT02M-XA+1GD	-	143-12FT02M-XA+1GD
40	30	20-1000	-	143-12NT03N-XA+1GD	-	143-12FT03N-XA+1GD
50	20	20-1000	-	143-12NV02N-XA+1GD	-	143-12FV02N-XA+1GD
50	30	20-750	-	143-12NV03N-XA+1GD	-	143-12FV03N-XA+1GD
50	30	20-1000	-	143-12NV03P-XA+1GK	-	143-12FV03P-XA+1GK

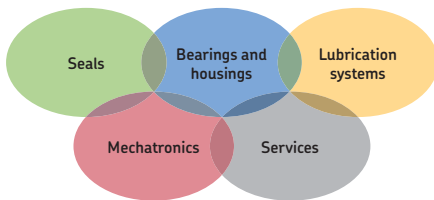

The Power of Knowledge Engineering

Combining products, people, and application-specific knowledge, SKF delivers innovative solutions to equipment manufacturers and production facilities in every major industry worldwide. Having expertise in multiple competence areas supports SKF Life Cycle Management, a proven approach to improving equipment reliability, optimizing operational and energy efficiency and reducing total cost of ownership.

These competence areas include bearings and units, seals, lubrication systems, mechatronics, and a wide range of services, from 3-D computer modelling to cloud-based condition monitoring and asset management services.

SKF's global footprint provides SKF customers with uniform quality standards and worldwide product availability. Our local presence provides direct access to the experience, knowledge and ingenuity of SKF people.

Further brochures:

- 1-0103-EN Fittings and Accessories*
- 1-1200-EN Gerotor, Gear and Camp Pumps*
- 1-1202-EN Gear Pump Units*
- 1-1203-EN Gear Pump Units Product Series MKx*
- 1-5006-EN Circulating Lubrication Systems*
- 1-9201-EN Transport of Lubricants in Centralized Lubrication Systems*
- 951-170-002 Assembly instructions with associated operating instructions*

SKF Lubrication Systems Germany GmbH

Berlin Plant
 Motzener Str. 35/37 · 12277 Berlin
 PO Box 970444 · 12704 Berlin
 Germany

Tel. +49 (0)30 72002-0
 Fax +49 (0)30 72002-111

This brochure was presented to you by:

© SKF is a registered trademark of the SKF Group.

© SKF Group 2014

The contents of this publication are the copyright of the publisher and may not be reproduced (even extracts) unless prior written permission is granted. Every care has been taken to ensure the accuracy of the information contained in this publication. However, no liability can be accepted for any loss or damage, whether direct, indirect or consequential, arising out of use of the information contained herein.

PUB LS/P2 14269 EN · July 2014 · 1-1204-3-EN

This publication replaces publication 1-1204-EN.

